



Installation Manual

General Information

Introduction 1
Warnings, Cautions, and Notes 1

Aqua-Hot Hydronic Heating System

Technical Information 3

Section 1: Safe Installation Requirements

Safety Warnings 4

Section 2: Aqua-Hot Installation

Location and Clearances 5
Mounting the Aqua-Hot 5
Installing the Expansion Tank 5
Installing the Electronic Controller 6

Section 3: Hydronic Heating System

Location and Clearances 12
Mounting Requirements 12
Mounting the Heat Exchangers 12
Wiring the Heat Exchangers 12
Plumbing Requirements 12
Plumbing the Hydronic Heating System 13

Section 4: Thermostats

Fresh Water Tank Thermostat Locations 21
Fresh Water Tank Thermostat Mounting 21
Fresh Water Tank Thermostat Wiring 21
Room Thermostat Locations 21
Room Thermostat Mounting 21
Room Thermostat Wiring 21

Section 5: Domestic Water System

Domestic Water System Requirements 23
Domestic Water System Plumbing 23

Section 6: Switch Panel

Locations 25
Mounting 25
Wiring 25

Section 7: Fuel System

Location 27
Fuel System Requirements 27
Fuel System Installation 27

Section 8: Engine Preheat System	
Location	30
Plumbing Requirements	30
Installing the Plumbing	30
Section 9: Exhaust System	
Exhaust System Requirements	32
Installing the Exhaust System	32
Section 10: Electric Wiring	
Electronic Controller Wiring	35
Diesel-Burner Controller Wiring	35
Connecting the 12 Volt-DC Power	36
Connecting the 120 Volt-AC Power	38
Installing AC Strain Relief Bracket	39
Section 11: Purging the Systems	
Purging the Hydronic Heating System	41
Purging the Engine Preheat System	42
Purging the Domestic Water System	42
Section 12: Initial Start-Up	
Activating the Aqua-Hot	46
Switch Panel Fault Indicator Light	46
Appendix A: Wiring Information	A1
Appendix B: Wire Gauge Chart	B1
Appendix C: Electronic Controller Features	C1
Appendix D:	
Antifreeze and Water Heating Solution	D1

Installation Manual Introduction

This Installation Manual is designed to aid in the installation process of the Aqua-Hot Hydronic Heating System by a trained and experienced technician. The Aqua-Hot features a 12 Volt-DC powered Diesel-Burner and a 120 Volt-AC, 1500 watt Electric Heating Element. These two heating sources are used in conjunction with an FDA approved "GRAS" (Generally Recognized as Safe) propylene glycol based antifreeze and water heating solution in order to provide a continuous supply of domestic hot water, interior/fresh water tank heating, independent interior zone heating, and engine preheating.

Please note that all Warnings, Cautions, and Notes, appearing as needed throughout this manual, must be reviewed and adhered to during the installation procedure in order to avoid potential hazards, which could result in personal injury, death, product damage, or property damage.

Should additional assistance be needed, please contact the Product Application Department at 1-800-685-4298, Monday through Friday, between the hours of 8:00 AM and 5:00 PM Mountain Standard Time.

Dangers, Warnings, Cautions, and Notes:

Danger, Warning, Caution, and Note boxes appear throughout this manual as a means of alerting the installer to important information.

DANGER!

Indicates that personal injury is likely or imminent.

WARNING!

Indicates that serious damage to the heater will occur and personal injury is possible as well.

CAUTION:

Indicates that damage to the heater is possible.

NOTE: Indicates information that requires special attention by the installer.

Aqua-Hot Hydronic Heating System

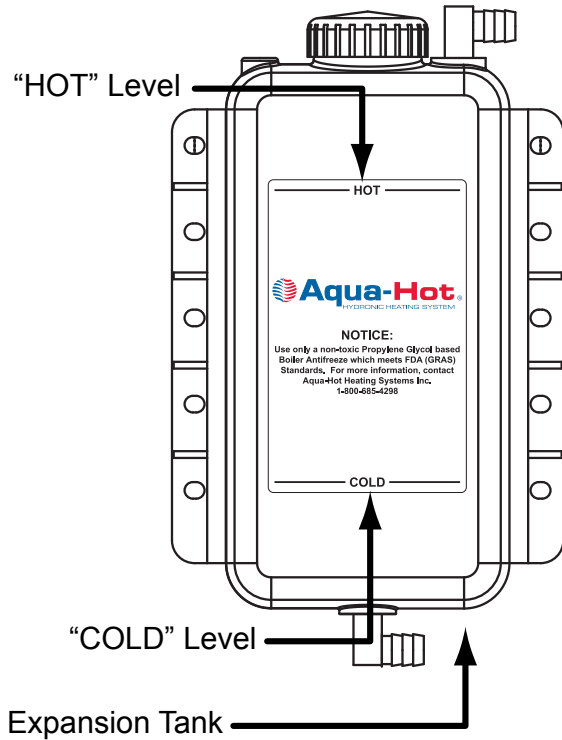
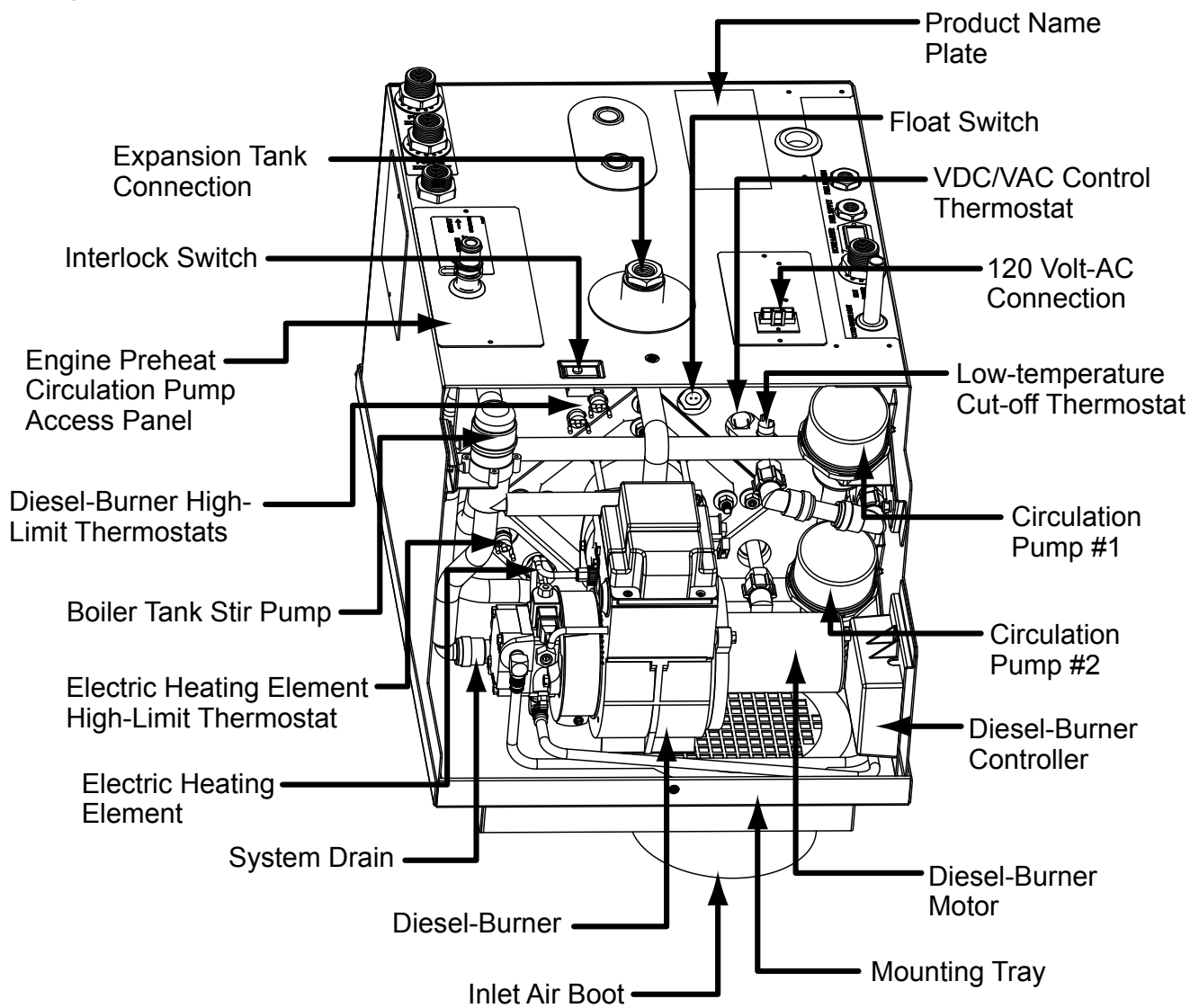

Figure 1



Aqua-Hot Hydronic Heating System

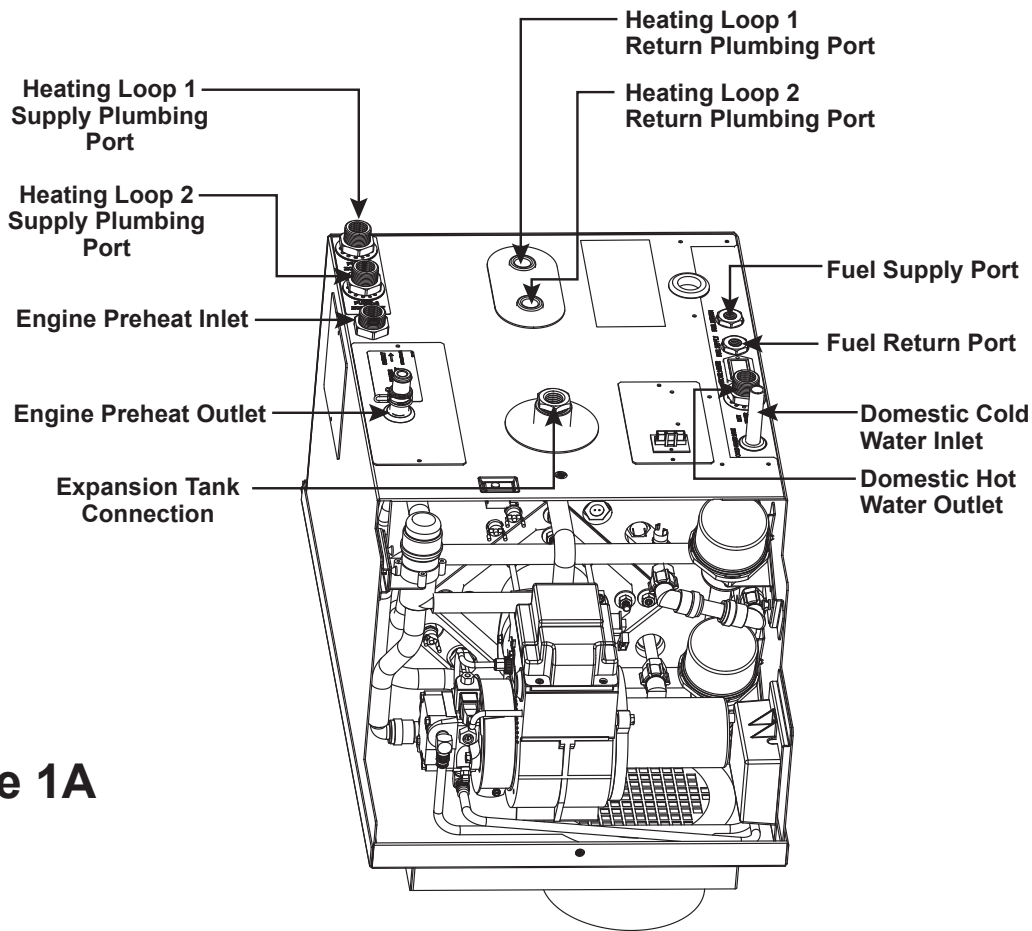

Figure 1A

Diesel-Burner, Heat Input (Firing Rate)	56,000 BTU/hr
Diesel-Burner, Fuel Consumption (Continuous Operation)	0.40 gal/hr
Heater, Voltage/Maximum Power Consumption	12 Volt-DC/210 watts
Electric Heating Element specifications.	120 Volt-AC/1500 watts
Zone Heat Circulation Pump specifications.	(2) 12 Volt-DC/21 watts each
Number of Heating Zones	maximum of 5, plus Engine Preheat
Domestic Water Heating Capacity.	continuous/on-demand
Dimensions	16.75" H x 18" W x 29.5" L
Dry Weight.	approximately 155 lbs.
Wet Weight	approximately 200 lbs.

NOTE: All vehicle installations must comply with the requirements listed in the Recreational Vehicle Industry Association's (RVIA) ANSI/NFPA 1192 Handbook for Recreational Vehicle Standards. To receive a copy of this Handbook and other pertinent RVIA Standards, write to: Recreation Vehicle Industry Association, 1896 Preston White Drive, P.O. Box 2999, Reston, VA 22090-0999, call them at (703) 620-6003, or visit them online at www.rvia.org.

Section 1: Safe Installation Requirements

WARNING!

Installation or repairs made by unqualified persons could potentially cause personal injury or death, as well as damage to the product or property. Installation **MUST** conform with all applicable Codes, Laws, and Regulations having the force of Law.

The information contained in this manual is intended for use by a qualified service technician who is experienced with Aqua-Hot Heating Systems, Inc.'s product installations, who is familiar with all precautions and safety procedures required in such work, and is equipped with the proper tools and test instruments.

Failure to carefully read and follow all instructions in this manual can result in product malfunction, death, personal injury, and/or property damage.

This appliance operates on both AC and DC power.

Water temperatures over 125°F can cause severe burns instantly or death from scalds.

Disabled children and the elderly are at the highest risk of being scalded.

DO NOT operate appliance with Access Covers removed.

The Combustion Air cannot be supplied from any compartment possibly containing combustible gases (e.g., Battery gases, Gasoline fumes, Propane fumes, etc.).

All Aqua-Hot Exhaust System Installations **MUST** utilize the two Black Pipe Nipples and the Black Pipe Elbow, which are provided with the Heating System, in the configuration best suited for the particular Recreational Vehicle application. Failure to conform could create a hazardous situation and will void the Aqua-Hot's ETL product listing.

Only propylene glycol based "boiler" type antifreeze deemed "GRAS" (Generally Recognized as Safe) by the FDA shall be used for the Aqua-Hot Hydronic Heating System. Failure to utilize the above-specified antifreeze type could result in serious injury or death.

The Aqua-Hot's exhaust is hot and must be kept away from any heat sensitive material. **DO NOT** direct exhaust downward as a fire may result when parked in dry, grassy areas. In addition, the exhaust must not terminate beneath the vehicle or beneath an openable window or vent. Refer to "Internal

Combustion Engine Exhausts and Vehicle Wall Openings" in RVIA's ANSI/NFPA 1192 Recreational Vehicle Standards Handbook, as well as the National Fire Protection Association's (NFPA) 1192 Standard on Recreational Vehicles, for additional information.

- **Certified for use in a Recreational Vehicle ONLY!**
- For Installation only in a compartment completely closed off from living quarters and accessible only from the outdoors.
- Exhaust System **MUST NOT** terminate beneath the vehicle or under an openable window or vent.
- Combustion Air **MUST BE** supplied from outside the vehicle.
- **Use Copper Conductors ONLY!**
- Use a 25 Amp fuse for over-current protection for the 12 Volt-DC Power supply.
- Install in strict compliance with local codes, NFPA 1192, and the manufacturer's instructions.
- Be sure to cut out the 14.375 inch by 18.250 inch hole for the Heater's Mounting Tray prior to placing the Aqua-Hot into the permanent mounting position. Reference Figure 4.
- Be sure to mount the Aqua-Hot securely to ensure that the unit does not move or shift under normal operating conditions.

Section 2: Aqua-Hot Installation

CAUTION:

The permanent mounting location must be capable of supporting a minimum of 300 lbs.

The Aqua-Hot cannot be installed anywhere inside the passenger compartment or any living area.

Exhaust must be able to freely exit away from the vehicle without any obstructions.

The Exhaust Pipe is **HOT** and must be kept away from any heat-sensitive material.

The Combustion Air cannot be supplied from any compartment possibly containing combustible gases (e.g., Battery gases, Gasoline fumes, Propane fumes, etc.).

Location and Clearances:

- Select a mounting location that is near a Storage Bay door (for ease of servicing) and requires a minimal length of exhaust pipe.

NOTE: Centralize the Aqua-Hot nearest the area where Domestic Hot Water will be used most frequently; reference Figure 13.

- The permanent mounting location must allow for mounting of the Electronic Controller within the allowable wire harness length.
- Reference the Product Name Plate on the Aqua-Hot and Figure 3 for minimum heater clearance information.

Installing the Mounting Tray and the Aqua-Hot Unit:

1. Reference the following illustrations for mounting information:
 - Overall Aqua-Hot dimensions - Figure 6
 - Mounting Tray information- Figure 4
 - Product Name Plate noting the "Open Access" clearance requirement for the front of the Heater - Figure 3
 - Service Access Clearances - Figure 5
2. Cut out the required Mounting Tray opening; reference Figure 4.
3. Install the Mounting Tray Flange into the cut-out opening; reference Figure 4.

NOTE: Be sure to secure the Mounting Tray into place prior to installing the Aqua-Hot unit.

Be sure to mount the Aqua-Hot securely into the Mounting Tray to ensure that the unit does not move or shift under normal operating conditions.

Be sure to provide an adequate support system for the mounting tray; if adequate support is not present, a cross-member will need to be installed. Reference Figure 4.

Inspect the area beneath the mounting location to insure no structural members will interfere with the cut-out for the mounting tray.

4. Insert a #10 Machine Screw into each of the embossed holes in the Mounting Tray (total of six required) and tighten to secure the Mounting Tray to the Motorhome.

NOTE: Remove the bolt securing the front of the access cover to the mounting tray; this bolt will need to be re-installed once the total installation procedure is complete. Remove the Access Cover; reference Figure 7.

5. Place the Aqua-Hot into the Mounting Tray; reference Figure 7.

Installing the Expansion Tank:

- Select a mounting location that allows for easy access and clear visibility whenever the particular Storage Bay door is open.

NOTE: The top of the Expansion Tank must always be mounted at least 4 inches higher than the Aqua-Hot's cabinet; reference Figure 8.

1. Mount the Expansion Tank as illustrated in Figure 8.
2. Connect and clamp the Overflow Tubing from the Expansion Tank to the Aqua-Hot's Expansion Tank Connection; reference Figure 8.

NOTE: Avoid any dips and bends in the overflow tubing from the Aqua-Hot to the Expansion Tank as air can become trapped in these dips and bends, preventing the expansion of the heating solution from properly depositing in the Expansion Tank. If necessary, cut tubing to desired length.

3. Drill a hole in the Bay floor and connect (secure with a clamp) a long enough piece of overflow Tubing so that it can be connected to the top of the Expansion Tank and extend through the Bay floor; reference Figure 8.

Section 2: Aqua-Hot Installation

Installing the Electronic Controller:

1. Select a mounting location for the Electronic Controller that meets the following:
 - The Electronic Controller should be mounted in the same Bay Storage Area as the Aqua-Hot and within the allowable length of the provided Wiring Harness.
 - The Electronic Controller must be easily visible, as the indicator lights can indicate a potential problem.
 - Due to the “Low Voltage Reset” button, the Electronic Controller must be easily accessible.

NOTE: The Electronic Controller can be either recessed or surface mounted.

2. To surface mount the Electronic Controller, secure the Electronic Controller’s Mounting Bracket to the Storage Bay’s wall with four (4) screws. Reference

Figure 2 for the location of the Surface Mounting Holes.

3. To recess mount the Electronic Controller, cut out a 7.25 inches W x 10.25 inches H opening and place the Mounting Bracket in the cut-out. Secure all four (4) Mounting Tabs to the wall. Reference Figure 2 for the location of the Mounting Tabs and the Recess Mounting Holes.
4. Once all wiring for the Aqua-Hot is complete, attach the Face Plate to the Mounting Bracket (reference Figure 2) and secure it with four (4) screws.

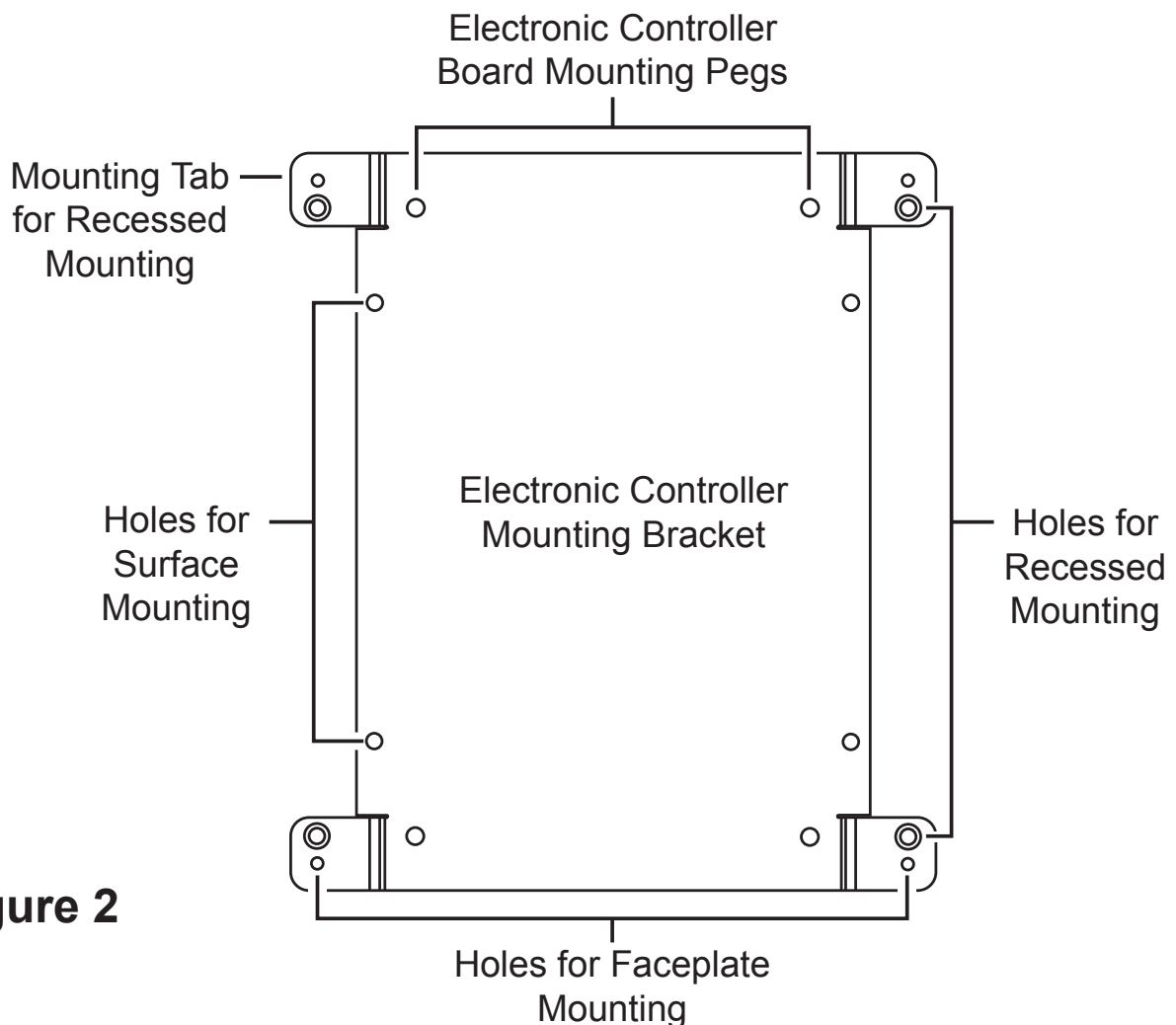



Figure 2



Aqua-Hot®

HYDRONIC HEATING SYSTEM

AHE-525		.35 / 60
Model Number	Serial Number	Nozzle Size/Angle
	DIESEL	12 VDC
Manufactured Date	Fuel Type	Volts
265	0 PSI	120 VAC, 50/60 Hz
Watts (DC)	Maximum Tank Pressure	Volts
1500		AH-5000
Watts (AC)	Diesel-Burner Serial Number	Diesel-Burner Model Number
57,000 BTU / 16.7 KW	125 PSI / 8.6 bar	
Input Firing Rate	Pump Pressure	



3069328

Certified for use in a Recreational Vehicle ONLY!

For installation only in a compartment that is completely closed off from living quarters and accessible only from the outdoors.

The Exhaust System MUST NOT terminate beneath the vehicle or under an openable window or vent.

Combustion Air MUST BE supplied from outside the vehicle.

 **CAUTION: THIS APPLIANCE OPERATES ON BOTH AC AND DC POWER.**

USE COPPER CONDUCTORS ONLY!

Use a 25-Amp fuse for overcurrent protection for the DC power supply.
 Use a 20-Amp Circuit Breaker for overcurrent protection for the AC Power supply.

Mount the Heater near a bay/storage door so that the Access Cover can be easily removed for service.

 **WARNING: DO NOT OPERATE APPLIANCE WITH ACCESS COVERS REMOVED.**

Minimum Heater Clearances:
 Front - Open Access
 Back - 0 inches
 Top - 0 inches
 Sides - 0 inches

Install in strict compliance with local codes, NFPA 1192, and the manufacturer's instructions.
 15549 East Highway 52 • Fort Lupton, CO 80621 • 1.800.685.4298 • www.aqua-hot.com

Figure 3

Section 2: Aqua-Hot Installation

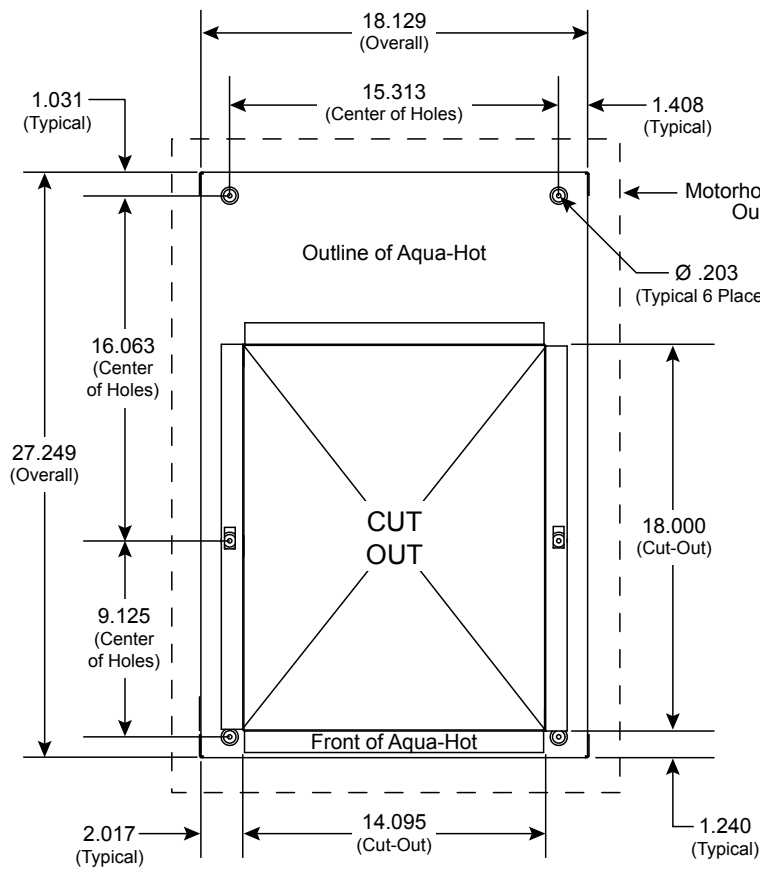
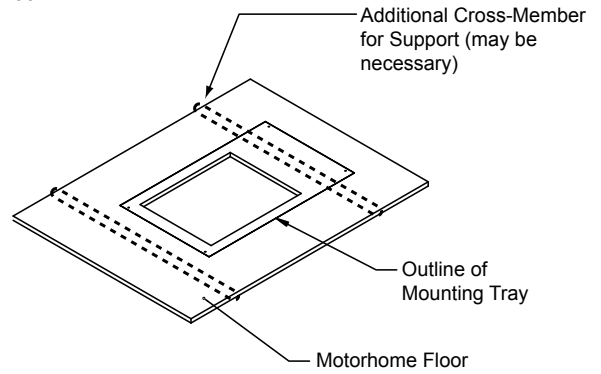
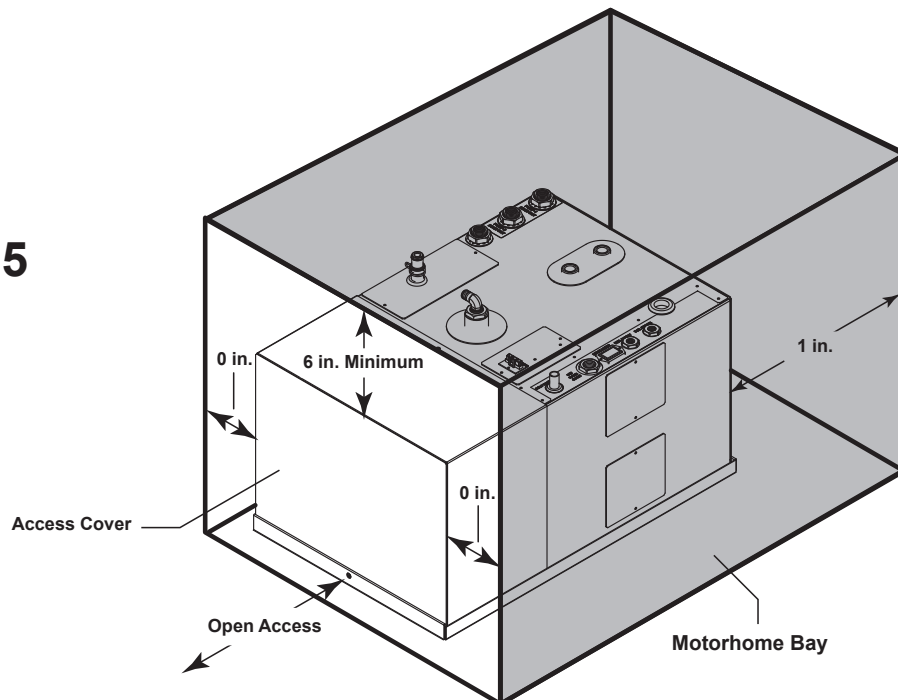

Figure 4



NOTE: All measurements are in inches

Figure 5



Section 2: Aqua-Hot Installation

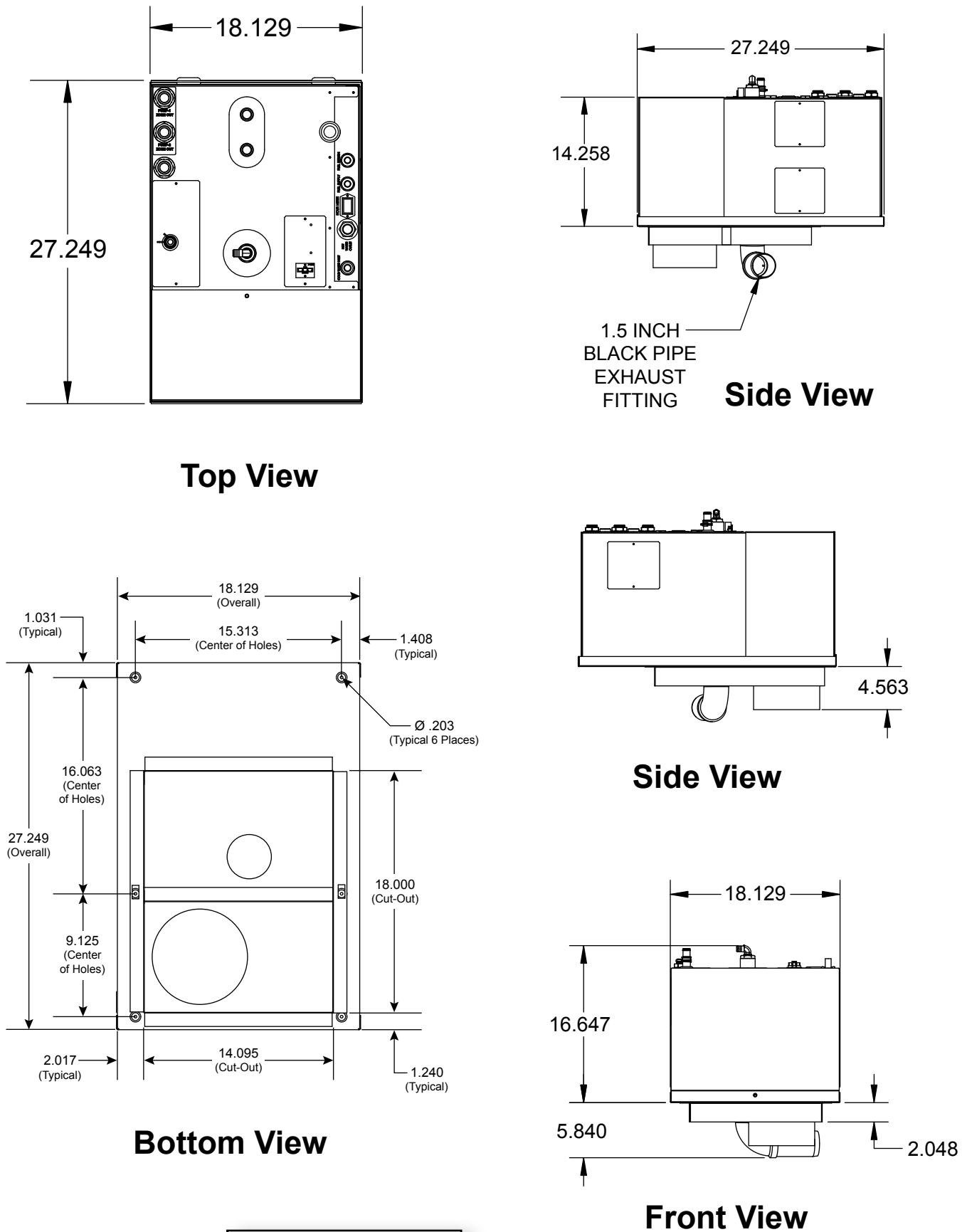

NOTE: All measurements are in inches.

Figure 6

Section 2: Aqua-Hot Installation

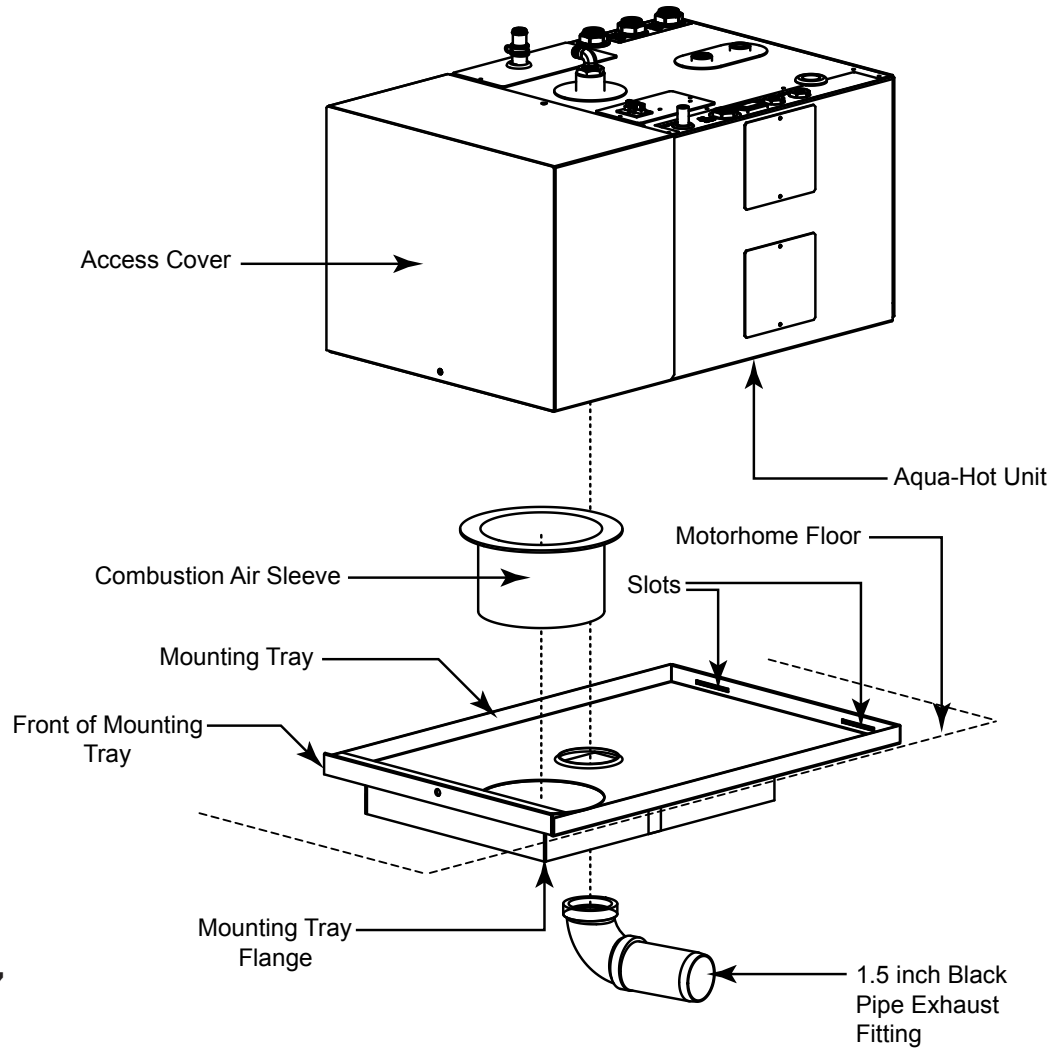
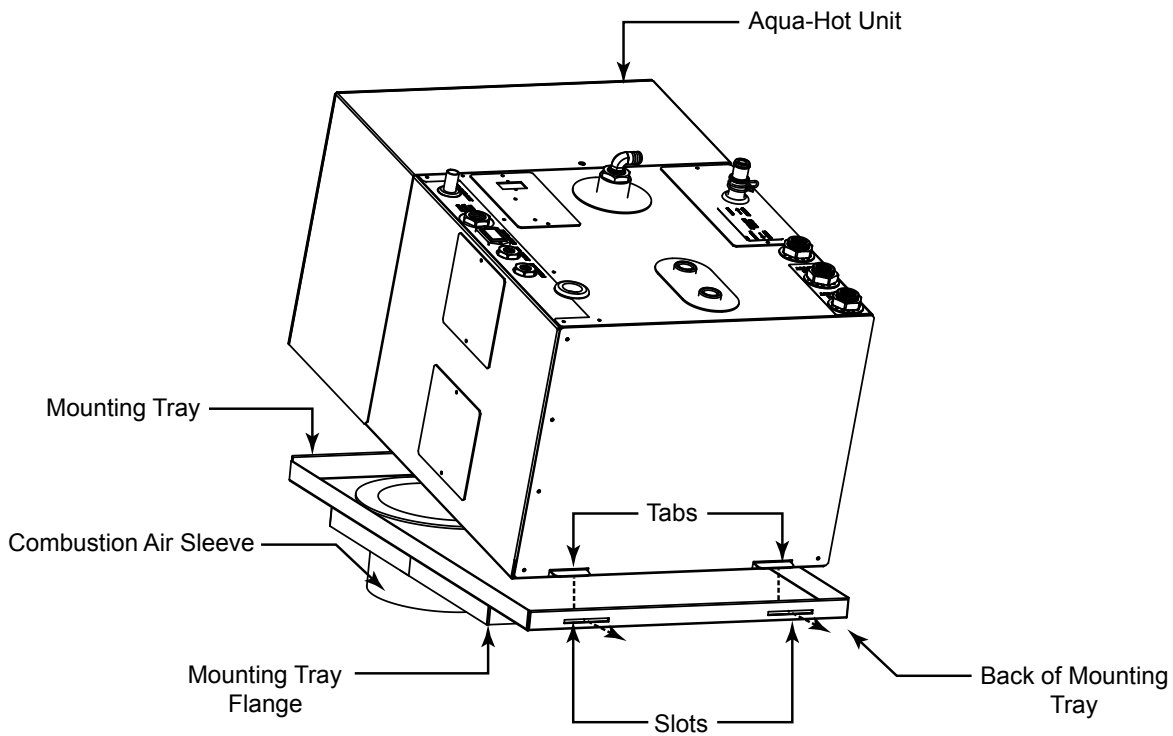

Figure 7



Section 2: Aqua-Hot Installation

NOTE: Avoid unnecessary dips and bends in the Overflow Tube as this can cause air to become trapped. If necessary, cut clear tubing to desired length. Also, for best results, mount the Expansion Tank as high as possible and practical. The top of the Expansion Tank must always be mounted at least 4 inches higher than the Aqua-Hot's Cabinet.

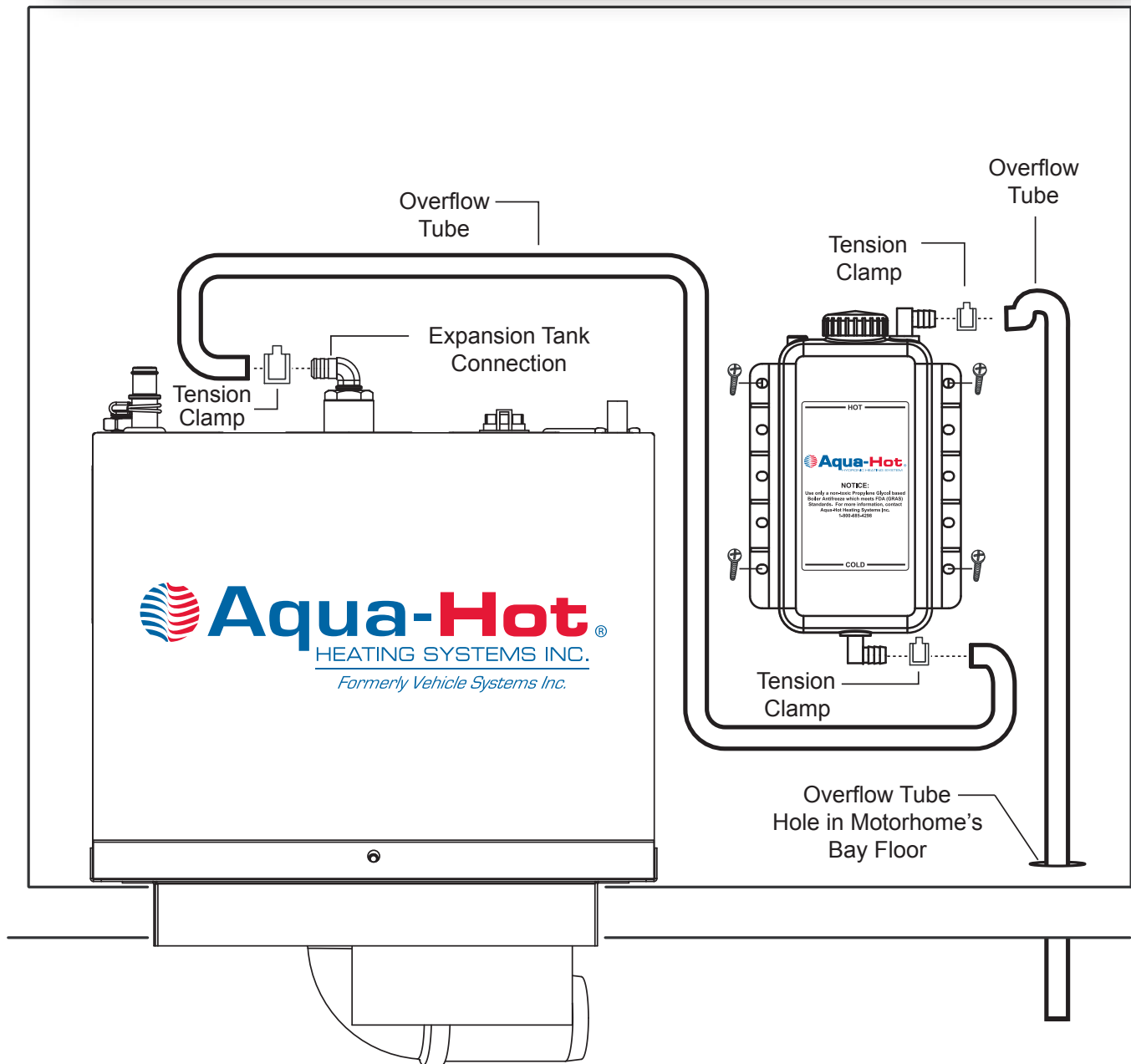

Figure 8

Section 3: Hydronic Heating System

Location and Clearances:

- Place the Heat Exchangers so that even-heat distribution will be felt throughout the interior of the motorhome; reference Figures 11 and 13.

NOTE: For single “Slideout” configurations, it is usually simplest to place a Heat Exchanger on the opposite side of the Motorhome pointing towards the Slideout.

- Place the Heat Exchangers where they will be accessible for potential servicing and cleaning.
- Centralize and position a Heat Exchanger in the Fresh Water Storage Tank Plumbing Bay.

NOTE: In order to achieve the best heating results, place the Heat Exchanger as close to the floor of the Plumbing Bay as possible (heat will naturally rise).

- Reference Figures 11 and 13 for mounting location information.
- Reference Figure 9 for clearance information.

NOTE: An accessory device is available for the Cozy III Heat Exchanger for the purpose of redirecting the airflow from the Heat Exchanger; reference Figure 10. Reference Figure 15

Mounting Requirements:

- Sufficient ventilation (return-air) must be supplied to each interior Heat Exchanger; reference Figures 11 and 14.

NOTE: Mounting the Heat Exchangers without sufficient ventilation will severely reduce their overall heating performance (heat output).

In order to provide sufficient ventilation, the “return-air” registers must be the same size, or larger, than the outlet-air registers.

“Return-Air” must be supplied from the corresponding interior heating zones.

Mounting the Heat Exchangers:

- Cut out a 2.5 inch x 10 inch opening for each Cozy III hot-air outlet and cold-air return register; reference Figure 14.
- Mount each Heat Exchanger permanently into

place; reference Figures 16 and 17.

- Install the hot-air outlet and cold-air return registers; reference Figure 14.

NOTE: Please note that a Return-Air Register may not be required; however, adequate return-air must be provided to each particular Heat Exchanger. This means that the total cross-sectional area of the return-air opening must be equal to or greater than the cross-sectional area of the hot-air outlet opening of the Heat Exchanger.

Wiring the Heat Exchangers:

- Run two 18 Gauge wires, Red for (+) and Black for (-) from each particular Heating Zone’s Heat Exchanger to the Electronic Controller.

NOTE: Run two wires from the closest Heat Exchanger to the Electronic Controller, then wire the other Heat Exchangers in-parallel for those heating zones with multiple Heat Exchangers; reference Figure 17 and Appendix A.

- Label the wires indicating the heating zone they pertain to (i.e., Living Room, Bathroom, Bedroom).
- Insert all Heat Exchanger wires into the appropriate terminal/heating zone location on the Electronic Controller (e.g., “#4 FAN + #4 FAN -” for the Fresh Water Tank Heating Zone, etc.); reference Appendix A.
- Connect all Electronic Controller “FAN” wires to the positive and negative leads of each Heat Exchanger; reference Figure 17 and Appendix A.

Plumbing Requirements:

NOTE: Once all Heat Exchangers have been mounted, formulate a plan for the routing of the Plumbing Lines from each heating zone to the Aqua-Hot.

All plumbing lines should be laid as flat as possible, and any extreme rises in height should be avoided to eliminate any potential air-traps.

- The Kitchen and Living Room Heat Exchangers (typically three) must be plumbed together **in-series** on “Heating Loop 1.” Reference Figures 13 and 18.
- The Fresh Water Tank, Bedroom, and Bathroom Heat Exchangers (typically 3) must be plumbed together **in-series** on “Heating Loop 2.” Reference Figures 13 and 18.

Section 3: Hydronic Heating System

- Use 5/8 inch I.D. (Inside Diameter) plumbing lines for both Heating Loops.
- Use wide-sweeping elbows or “Bend Supports” whenever the plumbing lines may be susceptible to kinking (i.e., 90° bends).

Plumbing the Hydronic Heating System:

1. Lay out the plumbing lines for all Heat Exchangers.
2. Label each line with the Heating Loop number and designate as a Supply or a Return line.

NOTE: All plumbing lines should be laid as flat as possible, and any extreme rises in height should be avoided to eliminate any potential air-traps.

Run all plumbing lines in areas where they cannot be pinched off or damaged under normal operating conditions.

Be sure to secure all lines where necessary and apply protective shielding in areas where chafing may occur.

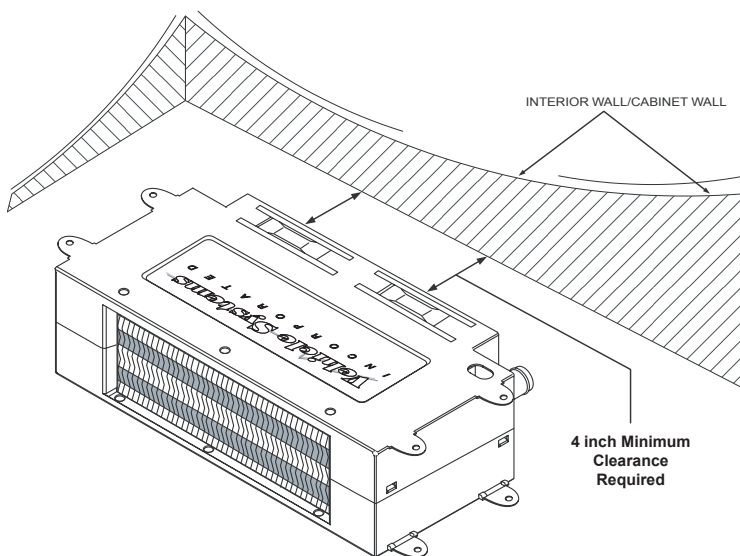

Figure 9

Rubber Coated/ Closed-Type clamps are recommended when securing the plumbing lines.

3. Connect and clamp the Supply line from the Heater to the lowest port on the closest Heat Exchanger for both Heating Loops; reference Figures 19 and 20. Then, connect each additional Heat Exchanger in the same arrangement (low to high).
4. Connect and clamp the Return line from the Heater to the highest port on the last Heat Exchanger for both Heating Loops; reference Figures 19 and 20.

NOTE: Reference Figure 20 for visual instructions on connecting PEX type tubing to each Heat Exchanger.

Plumbing Heat Exchangers in this manner will allow air to escape naturally. If air is trapped in any Heat Exchanger, it will significantly reduce the Heat Exchanger's overall heating performance (heat output).

5. Connect and tighten all interior plumbing lines, Supply and Return, to the Aqua-Hot's appropriate Heating Loop ports; reference Figure 21.

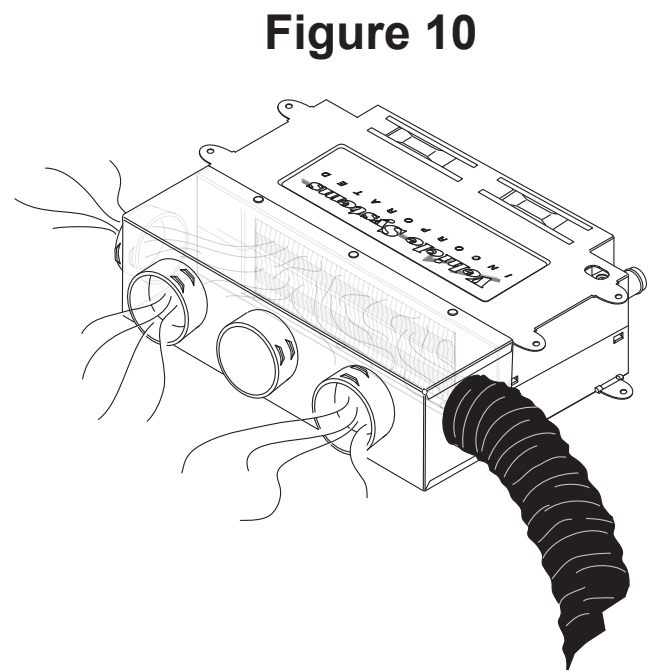

Figure 10

Section 3: Hydronic Heating System

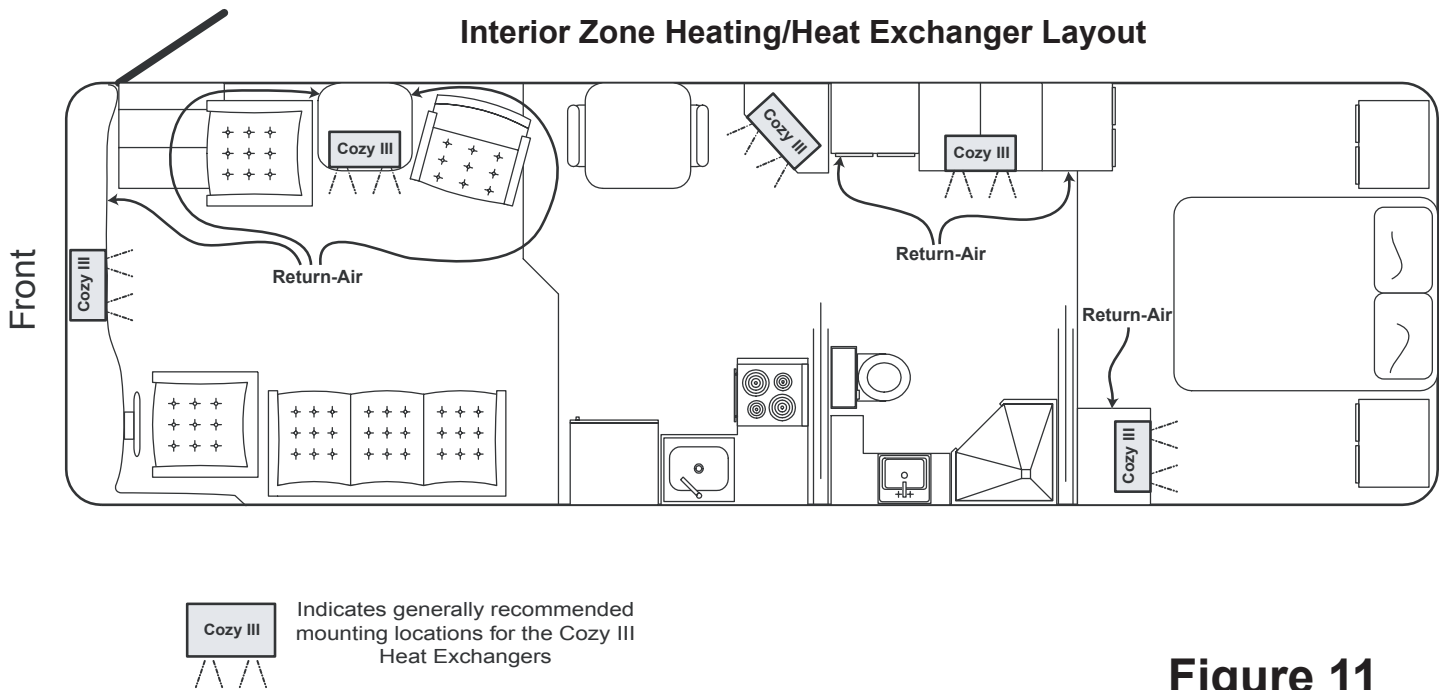
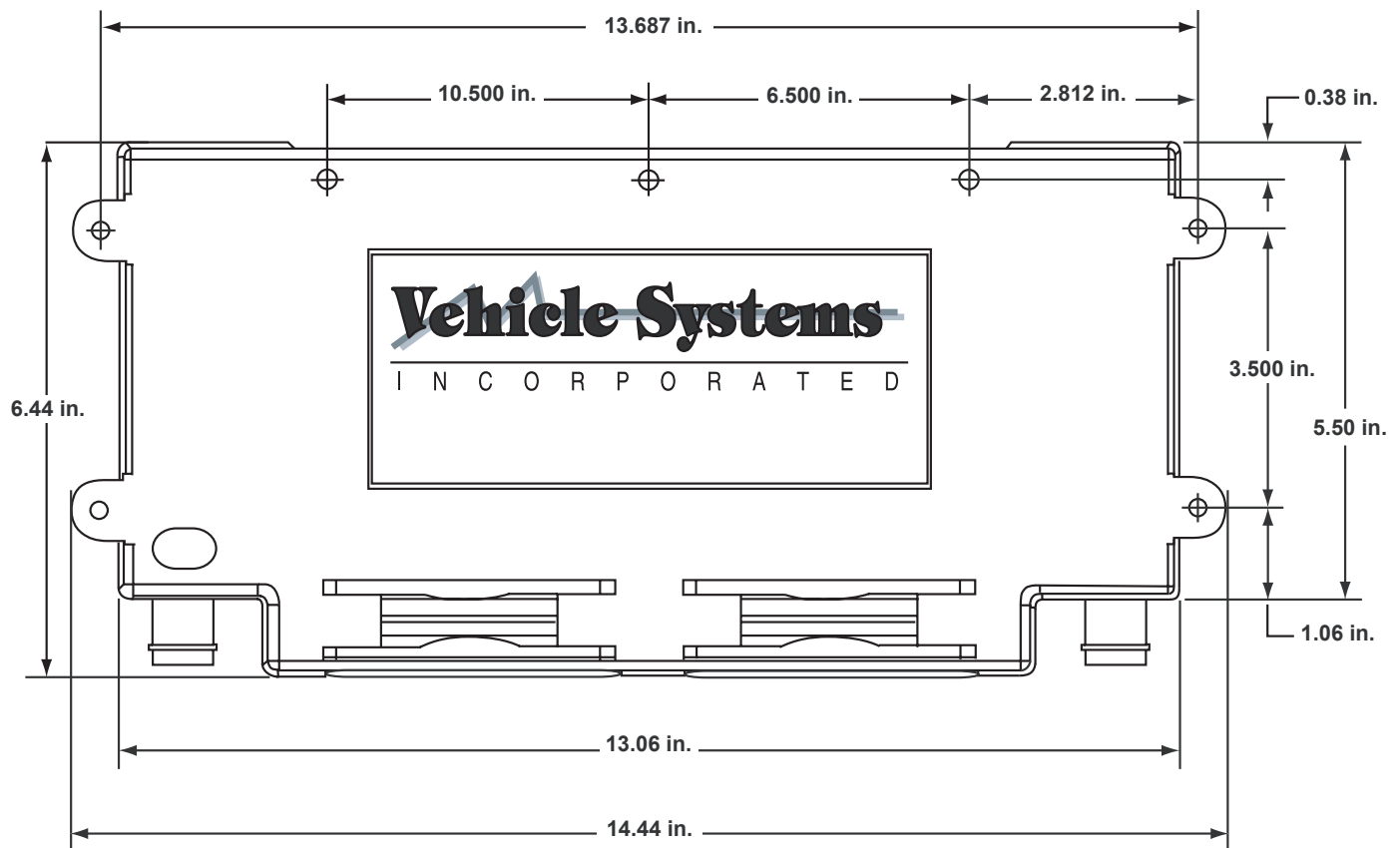

Figure 11



NOTE:

Tolerances on the dimensions shown are as follows:

.XX (i.e., 6.44 in.) = $\pm .030$

.XXX (i.e., 6.500 in.) = $\pm .015$

Figure 12

Generalized Motorhome Heating System Floor Plan

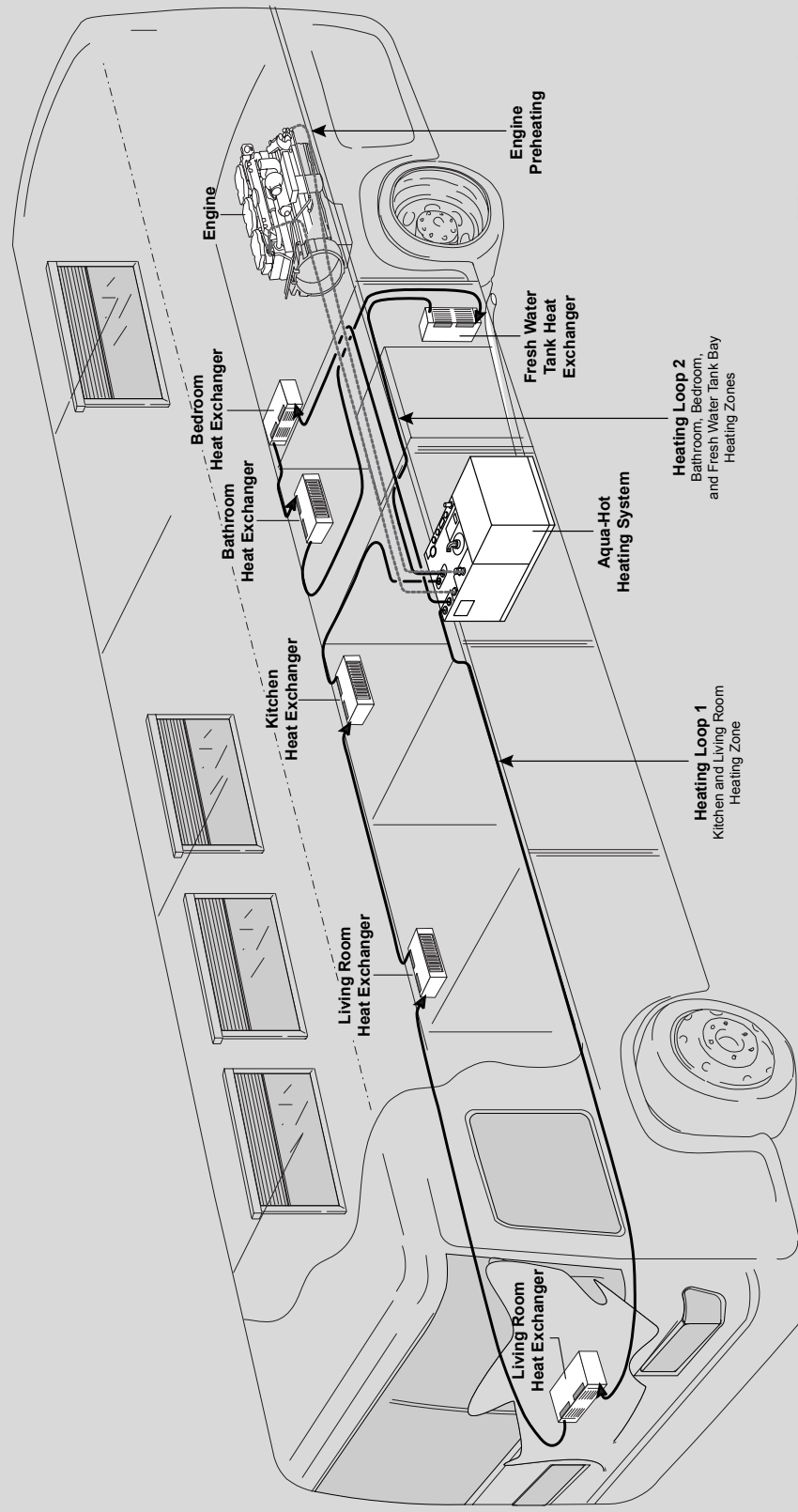

Figure 13

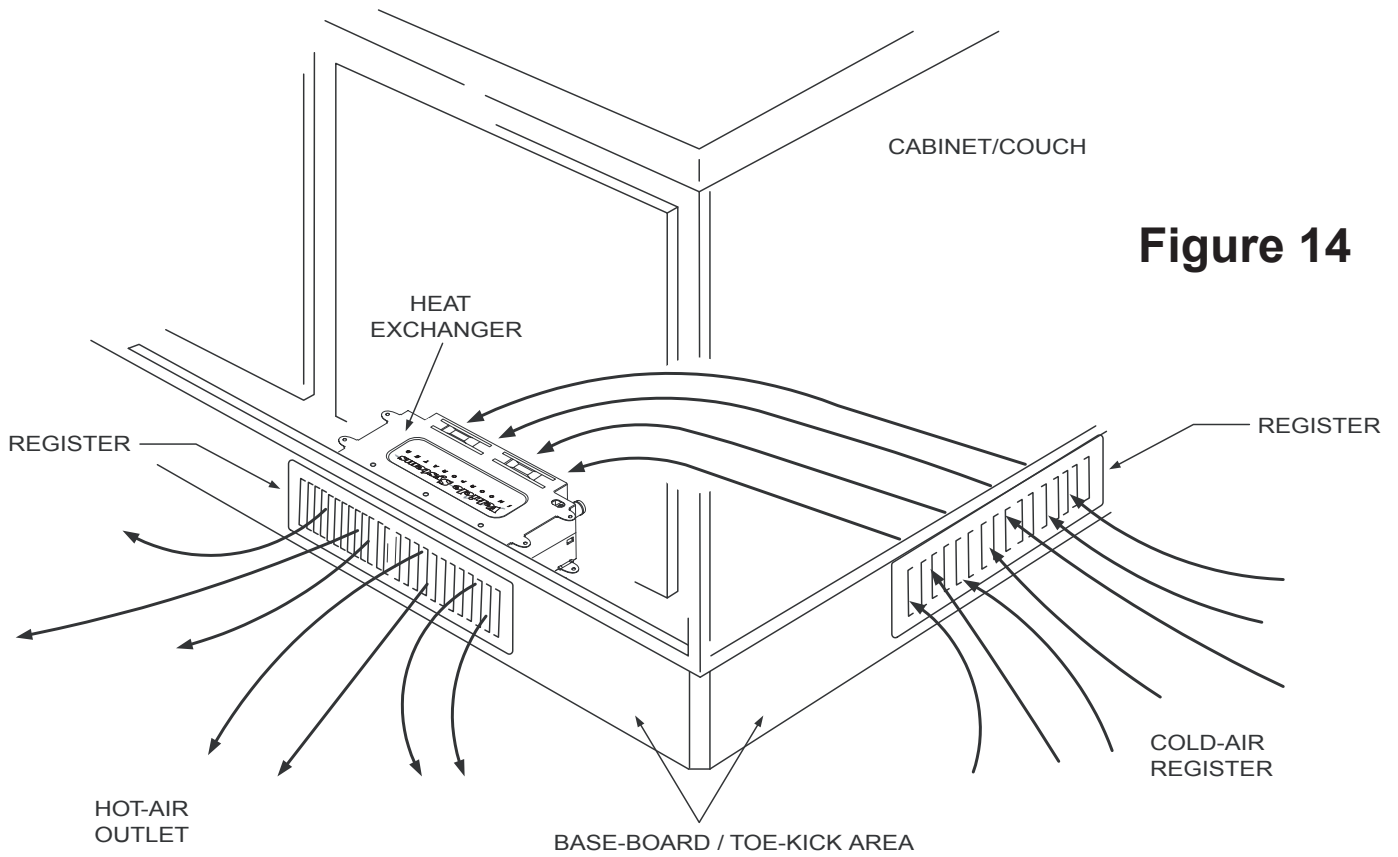

Figure 14

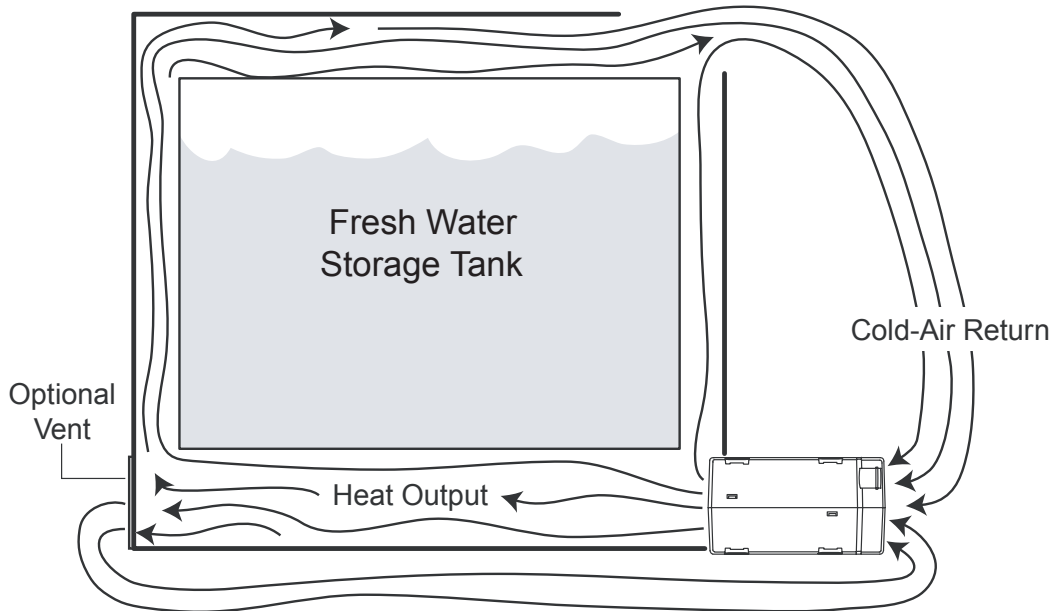
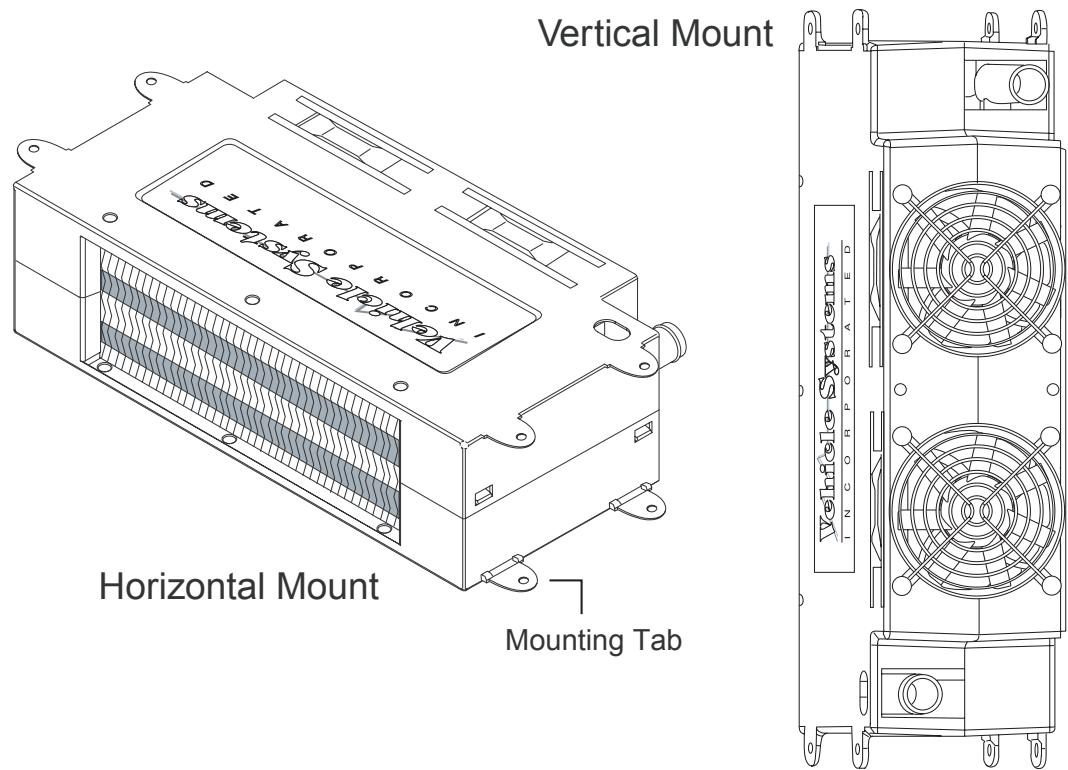

Figure 15

Section 3: Hydronic Heating System

Figure 16



NOTE: Tolerance
+/- .030

+ (Positive) Red Wires
To the "FAN +" connection
on the Electronic Controller

- (Ground) Black Wires
To the "FAN -" connection on
the Electronic Controller

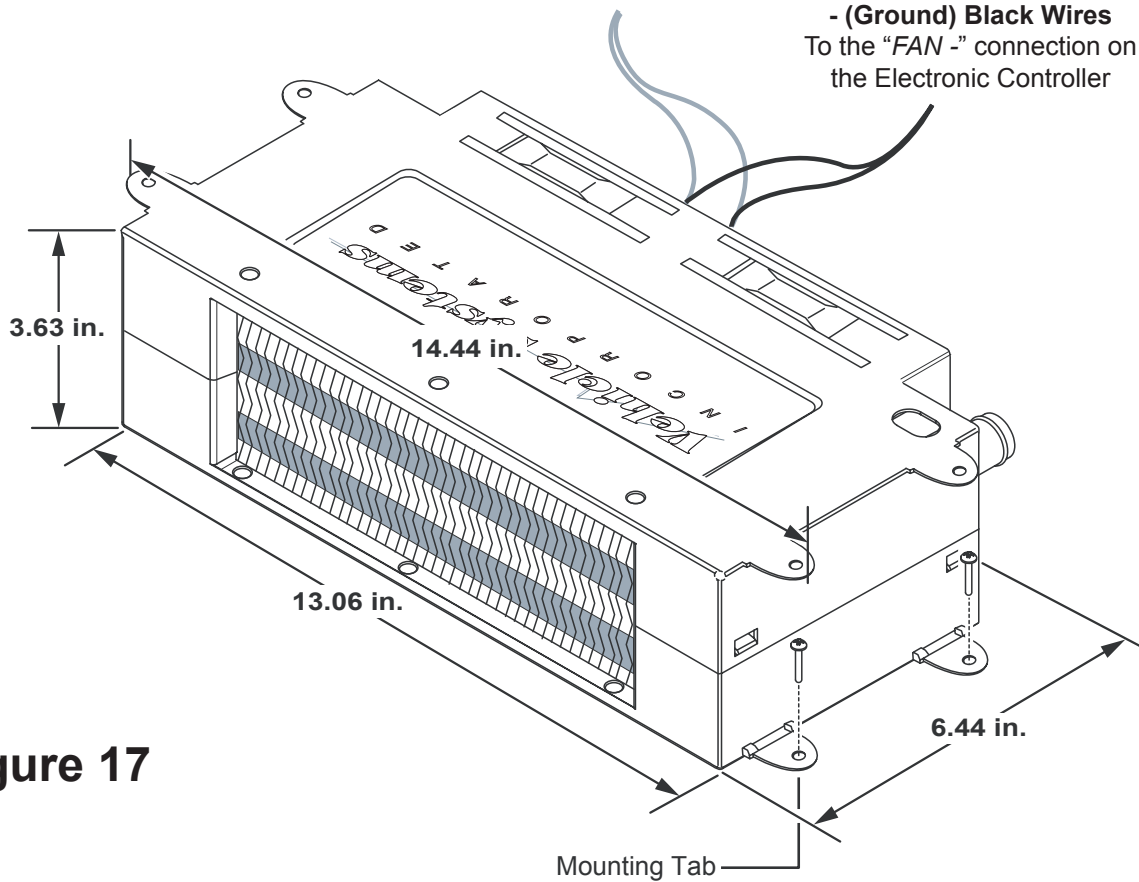
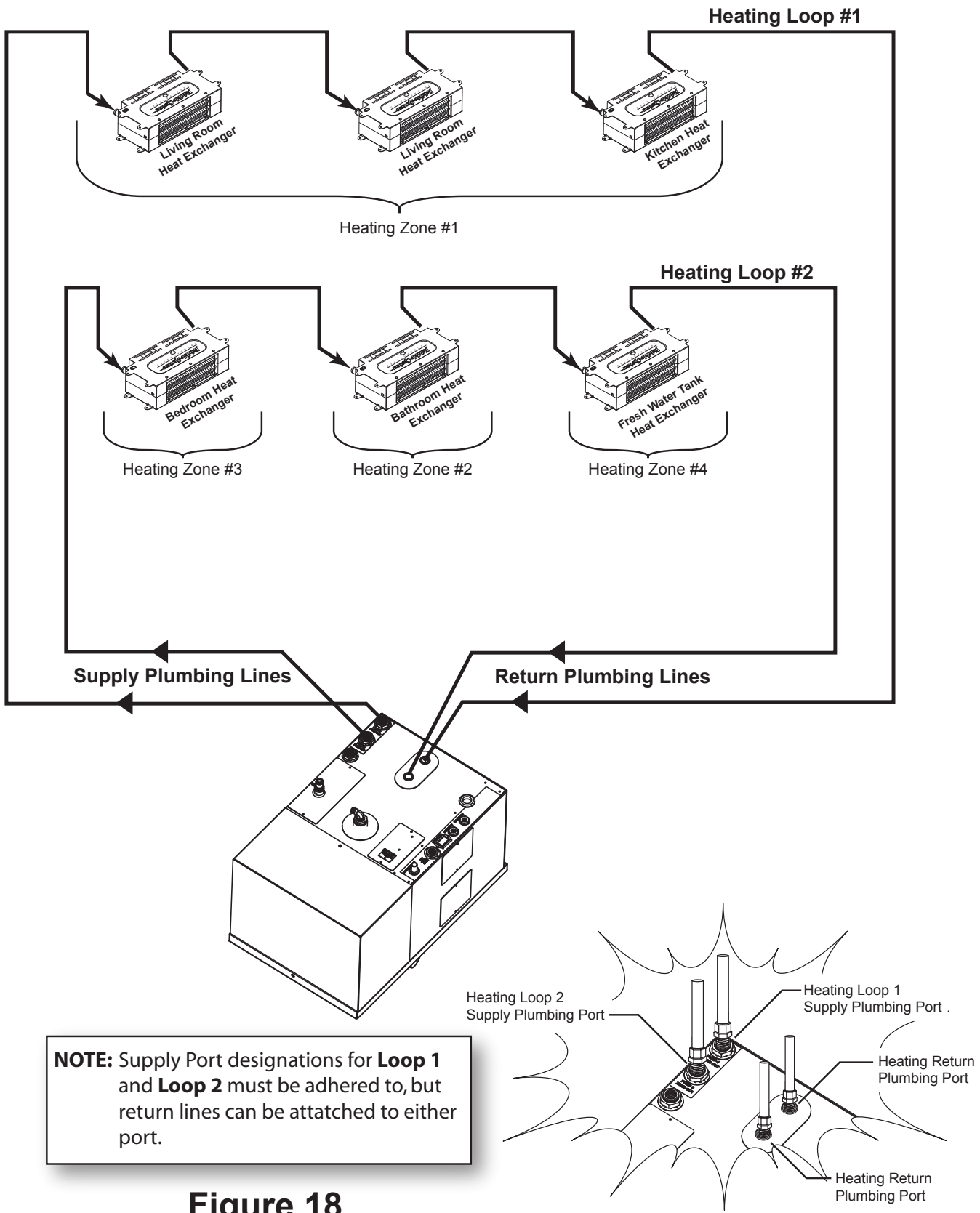

Figure 17

Section 3: Hydronic Heating System



NOTE: Supply Port designations for **Loop 1** and **Loop 2** must be adhered to, but return lines can be attached to either port.

Figure 18

Section 3: Hydronic Heating System

Cozy III Heat Exchanger (Rear View)

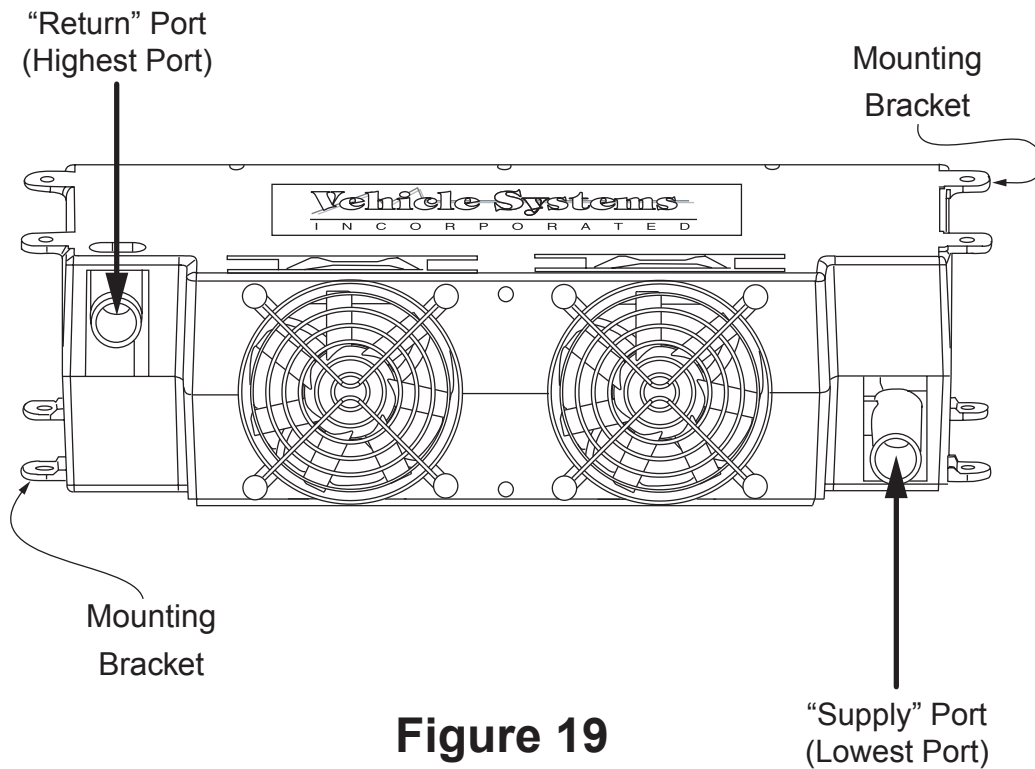
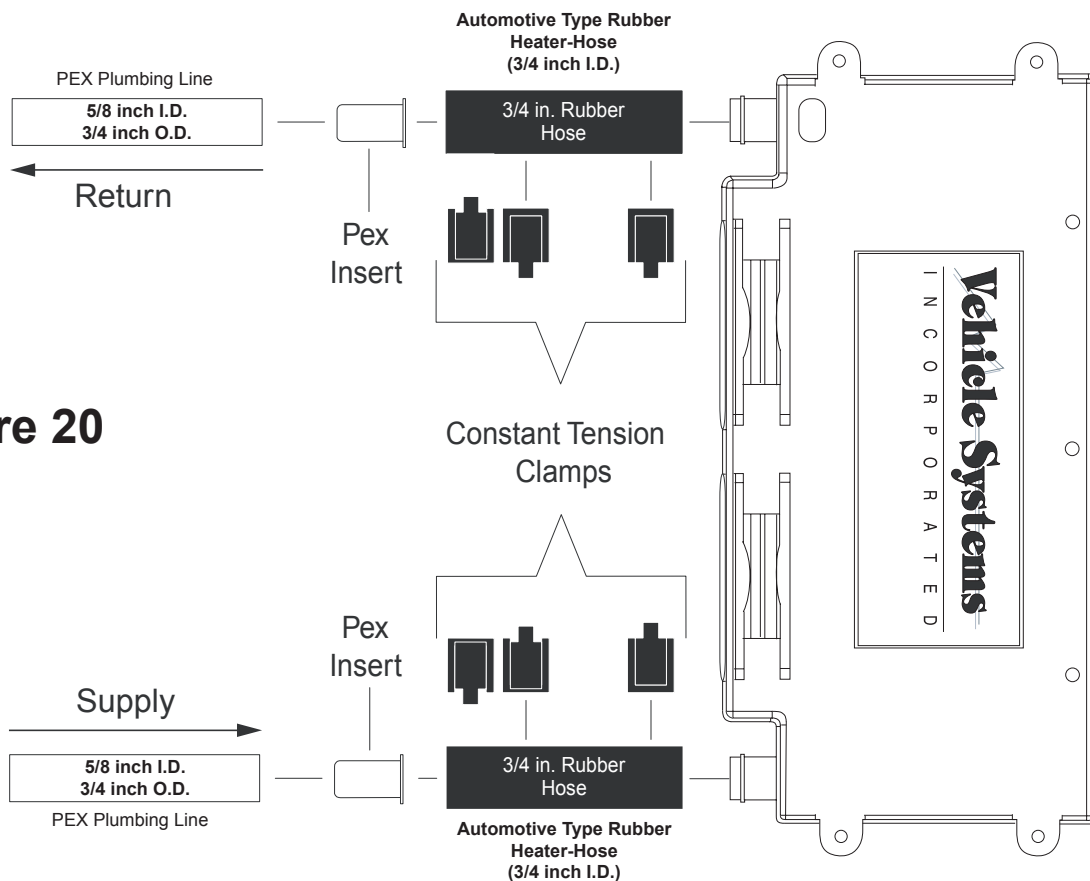
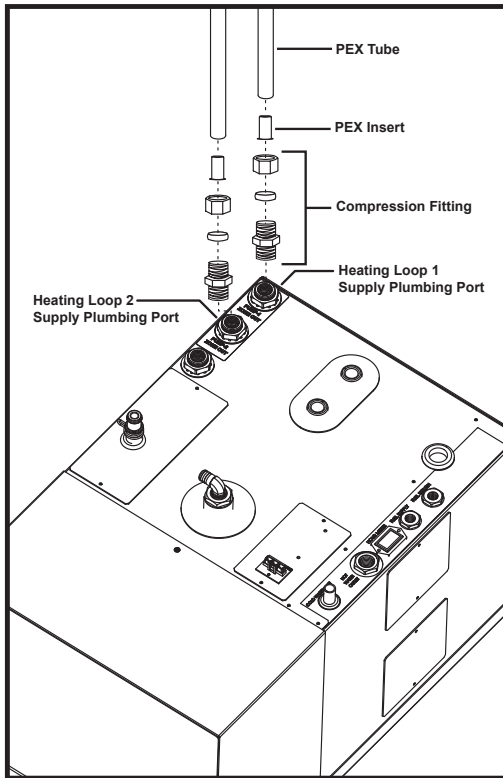

Figure 19

Figure 20



“Supply” Heating Loop Ports



“OPTIONAL”



“Return” Heating Loop Ports

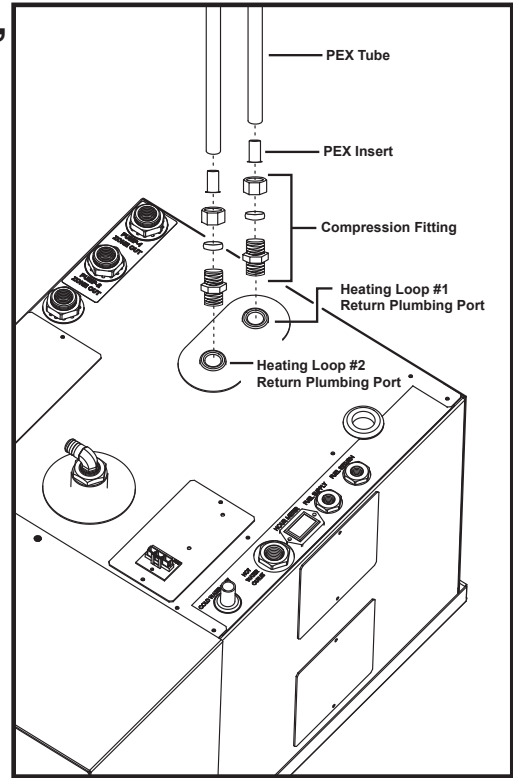

“Supply” Heating Loop Ports

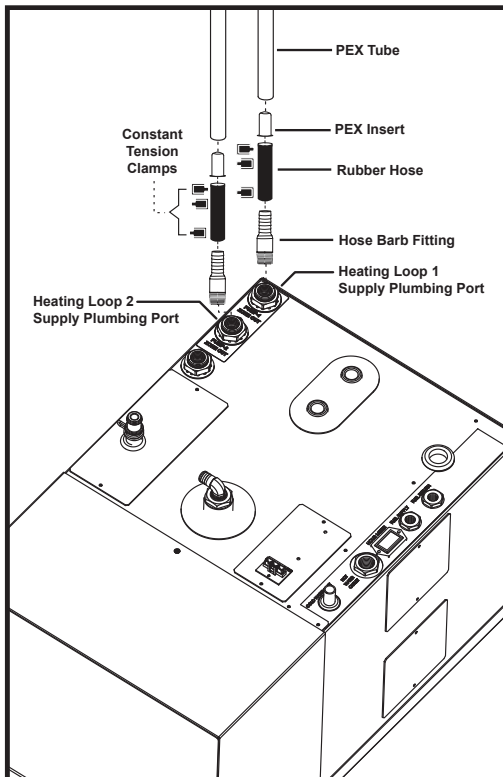
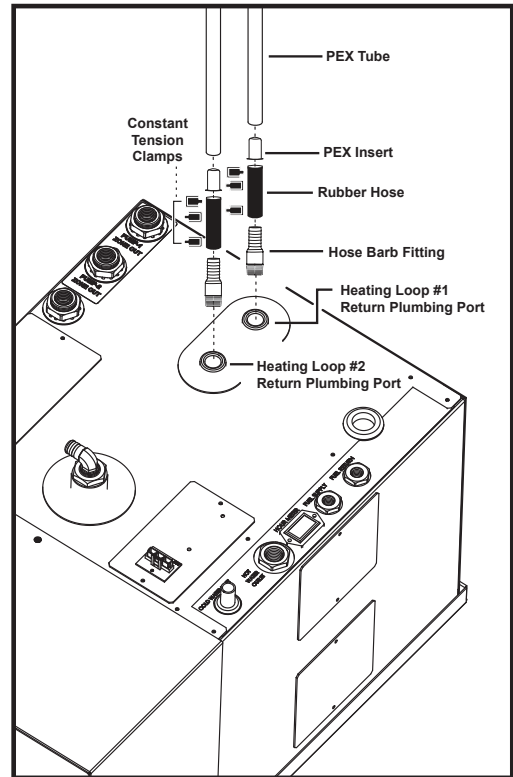

Figure 21

“Return” Heating Loop Ports



Section 4: Thermostats

Fresh Water Tank Thermostat Locations:

- Select a location that will ensure even-heat distribution throughout the Fresh Water Storage Tank bay compartment in order to prevent the domestic water and plumbing system from freezing.
- Typically only the “bulb” of the thermostat needs to be physically mounted in the area requiring heat (usually in close proximity to the domestic water pump); reference Figure 22.
- Do not mount the thermostat “bulb” in a drafty area.
- The selected mounting location should allow for easy operator access; reference Figure 22.
- Avoid mounting the Fresh Water Tank Thermostat’s “bulb” too close to the Bay Heat Exchanger.

Fresh Water Tank Thermostat Mounting:

1. Centralize the thermostat bulb in the Fresh Water Storage Tank bay compartment.
2. Once the thermostat has been completely wired, permanently mount the thermostat in place; reference Figure 22.

Fresh Water Tank Thermostat Wiring:

1. Run two 18 gauge wires from the thermostat’s mounting location to the Aqua-Hot’s Electronic Controller.

NOTE: It is recommended that the wire numbers in Appendix A be used when installing the Aqua-Hot in order to assist with differentiating between the separate Heating Zones and to aid Service Personnel with troubleshooting.

2. Insert both thermostat wires into the appropriate terminal/heating zone location on the Electronic Controller; reference Appendix A.
3. Connect both wires to the appropriate leads of the thermostat; reference Figure 22.

Room Thermostat Locations:

- Select a location that will ensure even-heat throughout each heating zone.
- Locate each thermostat at approximately chest level, if applicable.

NOTE: The selected location should prevent the thermostat from being affected by:

- drafts or dead spots behind doors and in corners
- hot or cold air from ducts
- radiant heat from the sun or appliances
- heat from concealed pipes and chimneys
- unheated or uncooled areas such as an outside wall behind the thermostat

Room Thermostat Mounting:

- Once the Room Thermostat has been wired, permanently mount the thermostat in place.
- Be sure to then turn **OFF** all interior room thermostats.

Room Thermostat Wiring:

1. Run two 18 gauge wires from each Room Thermostat mounting location to the Aqua-Hot’s Electronic Controller.

NOTE: It is recommended that the wire numbers in Appendix A be used when installing the Aqua-Hot in order to assist with differentiating between the separate Heating Zones and to aid Service Personnel with troubleshooting.

2. Insert all Room Thermostat wires into the corresponding zone number location on the Electronic Controller; reference Appendix A.
3. Connect all wires to the appropriate leads of each Room Thermostat.

CAUTION:

The Aqua-Hot’s Electronic Controller is designed to work with most Electronic Room Thermostats; however, the chosen thermostat must output a constant 12 Volt-DC power supply and must receive its 12 Volt-DC Power Supply from the Aqua-Hot’s Electronic Controller (i.e., “THERM-O”). This will ensure that the thermostat and Electronic Controller are properly fuse protected.

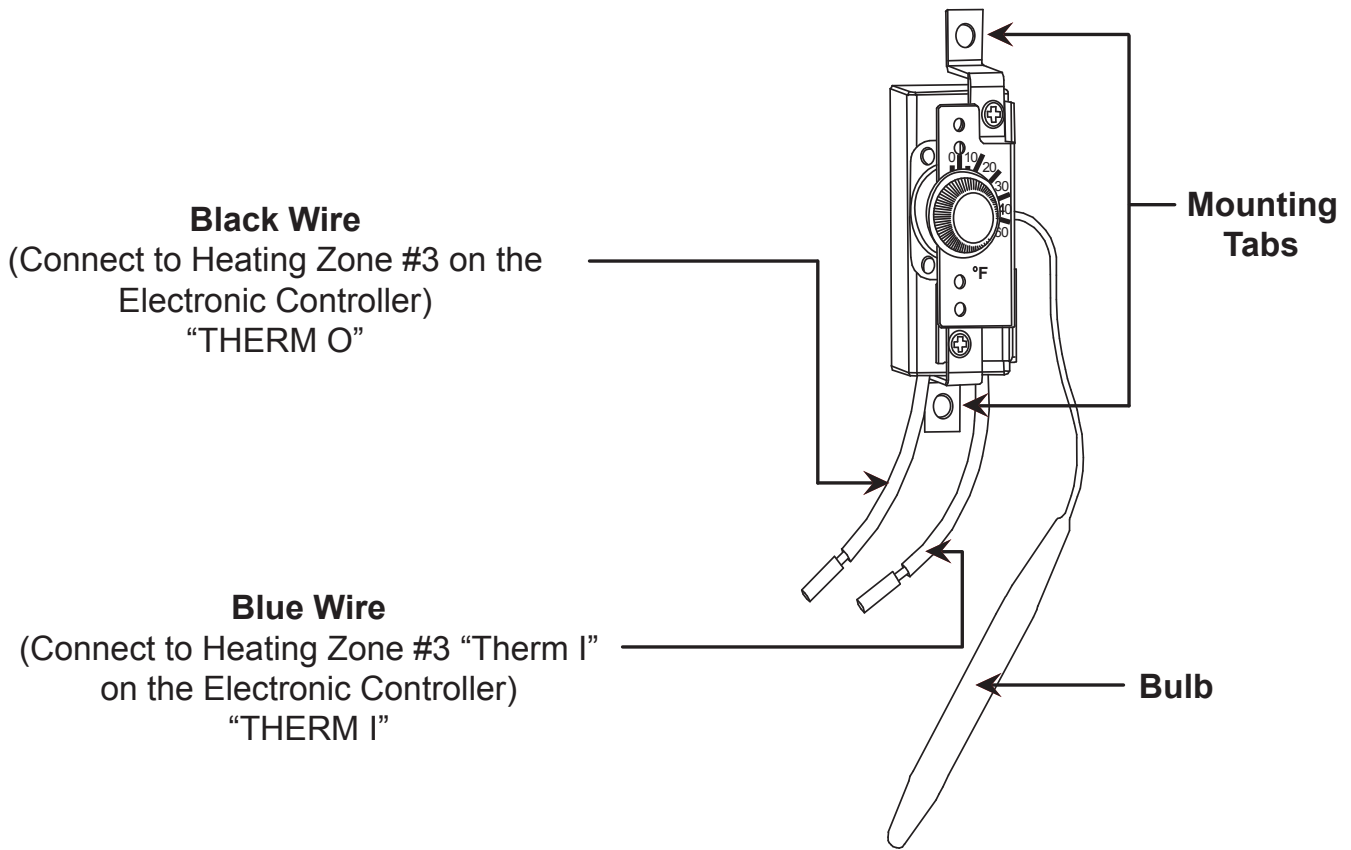

Figure 22

Section 5: Domestic Water System

NOTE: Please note that it may be necessary to utilize an Accumulator Tank within the Domestic Water System; reference Figure 24. Although the Aqua-Hot is equipped with a Pressure-Relief Valve, the use of an Accumulator Tank will help prevent excessive “weeping” of the aforementioned valve, if applicable. Manufacturers of Pressure-Relief Valves indicate that excessive weeping of these valves will cause the “seat” in the valve to deteriorate, and, in turn, the valve will fail prematurely. For additional information regarding Accumulator Tanks, please be sure to reference the Recreational Vehicle Industry Association’s (RVIA) technical publication titled “Recreational Vehicle Plumbing Systems.” To obtain a copy of this particular publication, please contact RVIA at (703) 620-6003 or visit them online at www.rvia.org.

NOTE: The Aqua-Hot is equipped with a Pressure-Relief Valve, which releases excessive pressure in the Domestic Water System, if necessary, as well as a Tempering Valve in order to regulate the temperature of the hot water.

NOTE: As stated directly from the ANSI A119.2/NFPA 501C Standard on Recreation Vehicles, 1993 Edition:

“Piping Systems shall be sized to provide an adequate quantity of water to each Plumbing Fixture at a flow rate sufficient to keep the Fixture in a clean and sanitary condition without any danger of back-flow or siphoning.”

Domestic Water System Plumbing:

Domestic Water System Requirements:

- Use the RVIA-provided table below in order to determine the proper sizing of pipe and tubing required to ensure maximum efficiency.
- The size of Water Supply Piping and Branch Line shall not be less than specified in the table below.

1. Connect a domestic water Plumbing Line from the Domestic Water Demand Pump/Water Manifold to the Cold Water Inlet port on the Aqua-Hot; reference Figures 23 and 24.
2. Connect a domestic water Plumbing Line from the Aqua-Hot’s Hot Water Outlet port to the hot water system’s Distribution Lines/Water Manifold; reference Figures 23 and 24.

NOTE: A water heater or ice maker shall not be counted as a “water-using fixture” when computing pipe sizes.

Minimum Size Tubing and Pipe for Water Distribution Systems* Table

Number of Fixtures	Tubing		Pipe
	Inner Dia. (inches)	Outer Dia. (inches)	Iron Pipe Size (inches)
1	1/4**	3/8**	3/8
2	1/4***	3/8***	3/8
3	3/8	1/2	1/2
4	3/8	1/2	1/2
5 or more	1/2	5/8	1/2

* Minimum size for toilet water supply line shall not be less than the size recommended by the toilet manufacturer

** 12-feet (3.7 m) maximum length allowable only from water service connection to a single fixture.

*** 6-feet (1.8 m) maximum length

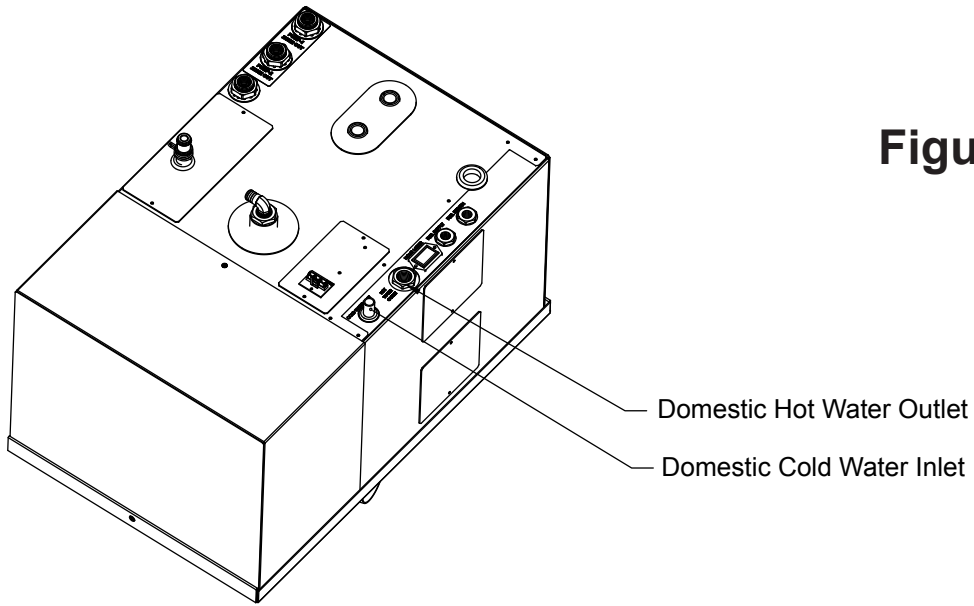
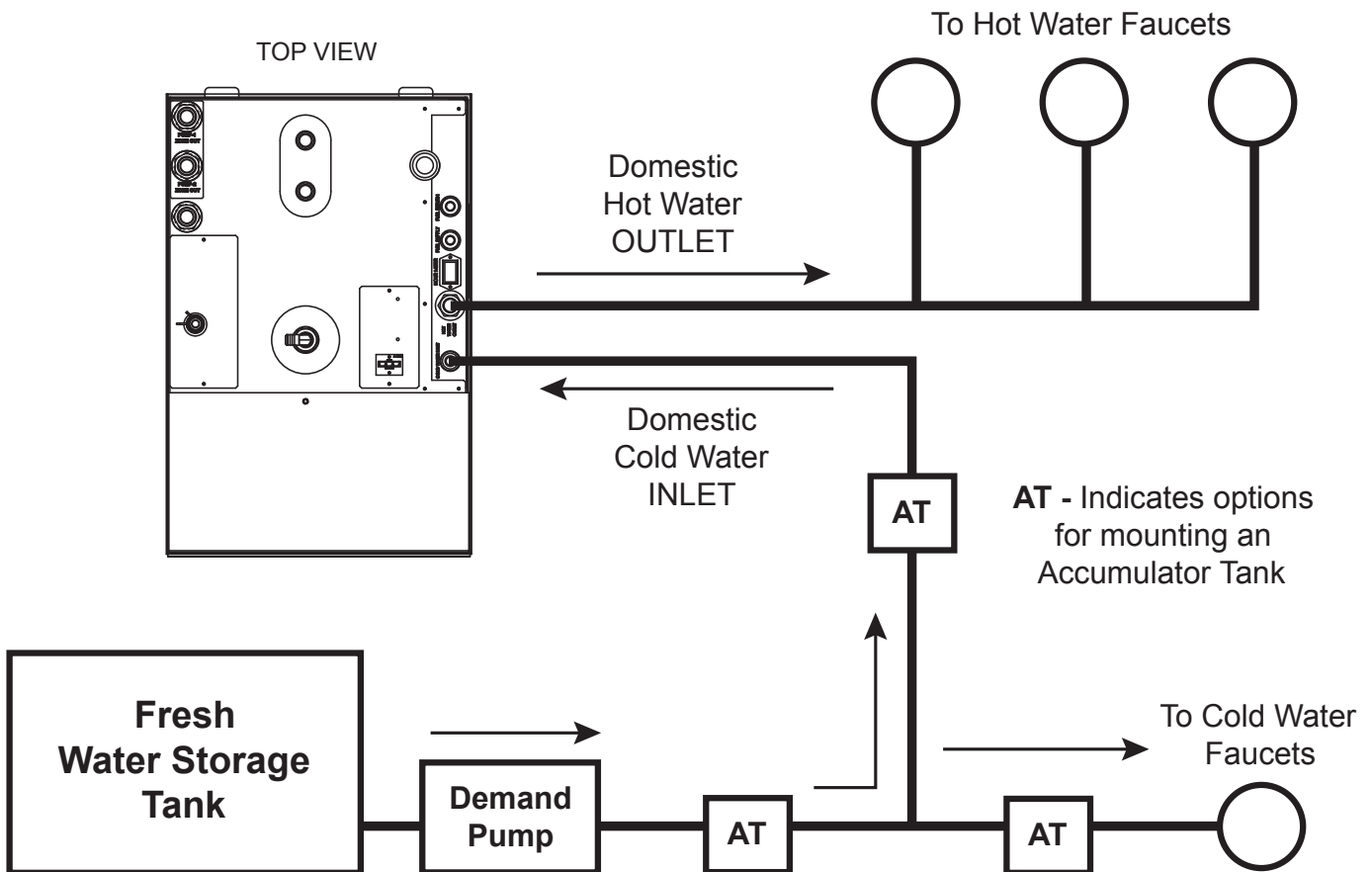

Figure 23

Figure 24

Arrows indicate directional flow of domestic water



Section 6: Switch Panel

Switch Panel
Back Side View

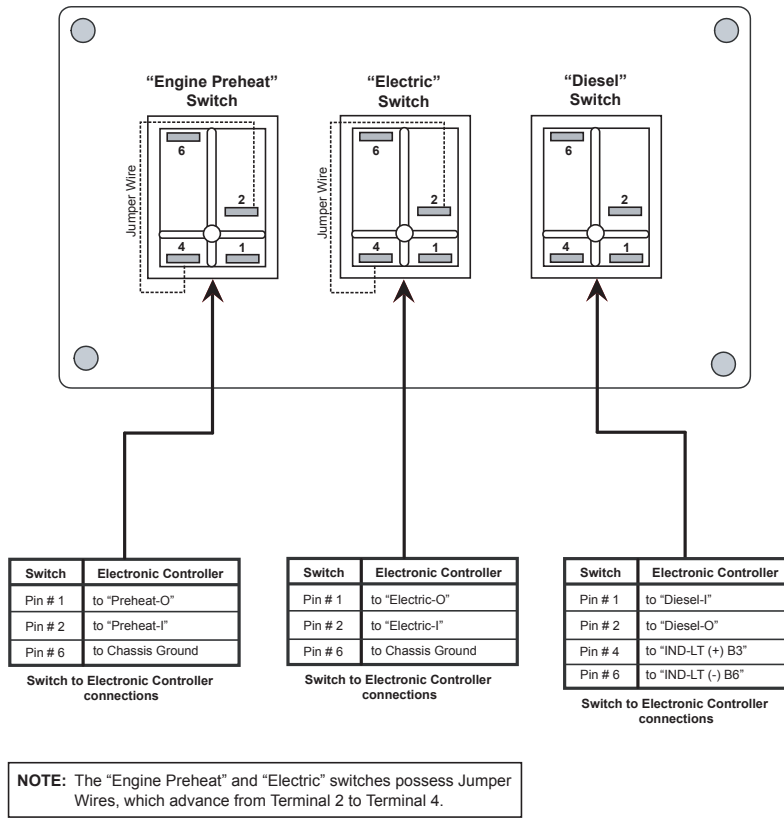

Figure 26

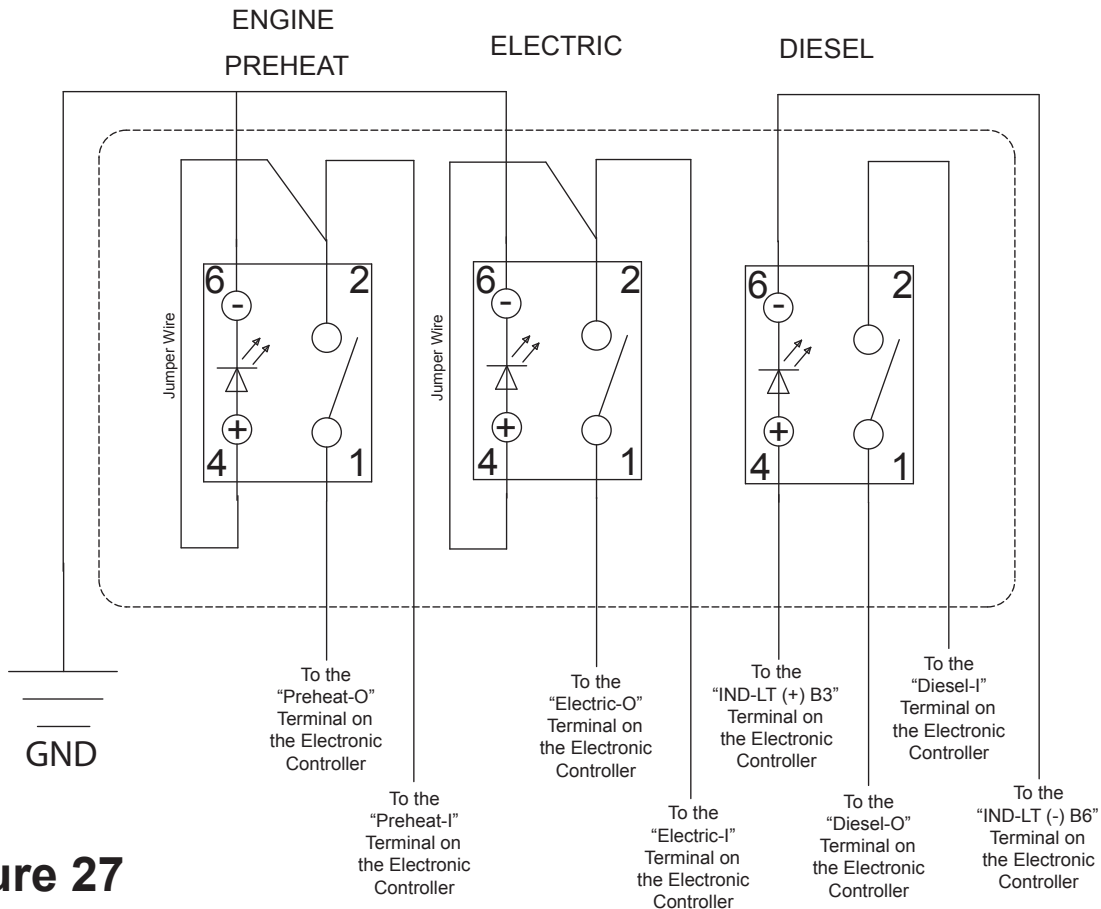

Figure 27

Section 7: Fuel System

CAUTION:

A kinked Fuel Line (Return side) will increase the fuel pressure to hazardous levels and may cause a Fuel Line to rupture. A kinked Fuel Line could also severely damage the Diesel-Burner's internal fuel system.

Location:

- Mount the Fuel Filter in a location that provides easy access for changing the Filter Element and for catching any potential fuel spillage when servicing.

Fuel System Requirements:

- The diesel fuel supply should be drawn directly from the Vehicle's main Fuel Tank or from a separate auxiliary Fuel Tank, if applicable.
- The Fuel Tank should be equipped with a dedicated Fuel Pick-Up Pipe ("Supply" port and "Return" port); reference Figure 28.

NOTE: If an auxiliary Fuel Tank is required, be sure to consult the ANSI/NFPA 1192 Handbook Manual concerning Heating Systems' Diesel Fuel System specifications.

Also, be sure to reference the ANSI/NFPA 1192 Handbook for information regarding Fuel Distribution System specifications.

- Fuel head pressure should not exceed 10 feet; reference Figure 29.
- Use 3/8 inch I.D. Fuel Lines.
- The combined length of the supply and return Fuel Lines should not exceed 100 feet in total length; reference Figure 29.
- All fuel-fitting hardware (i.e., at the vehicle's fuel tank, fuel filter, and Aqua-Hot fuel ports) must be 1/4 inch NPT or greater with a 3/8 inch barbed fitting. Fuel fittings less than 1/4 inch NPT may restrict fuel flow, thereby compromising the Diesel-Burner's performance.

Fuel System Installation:

1. Run two 3/8 inch Fuel Lines from the Fuel Tank/ Fuel Pick-Up to the Aqua-Hot.

NOTE: Both Fuel Lines should be laid as flat as possible and any extreme rises in height should be avoided in order to eliminate any potential air-traps.

Run both Fuel Lines in areas where they cannot be pinched off, kinked, or damaged during normal operating conditions.

Be sure to secure all Fuel Lines where necessary and apply protective shielding in areas where chafing may occur.

2. Label both Fuel Lines indicating whether they are a Supply line or a Return line.
3. Connect the Supply and Return Fuel Lines to the Fuel Tank/Fuel Pick-up Pipe; reference Figure 28.
4. Install and tighten the appropriate fuel fittings onto the Aqua-Hot's Fuel Ports, as well as the two ports of the Fuel Filter; reference Figures 30 and 31.

NOTE: The Supply Fuel Line must first connect to the Fuel Filter before proceeding to the Aqua-Hot.

5. Connect the Supply and Return Fuel Lines to the Aqua-Hot's Fuel Port connections; reference Figure 30.
6. Cut the Supply Fuel Line at the Fuel Filter mounting location and connect the Fuel Lines as illustrated in Figures 29 and 31.

Figure 28

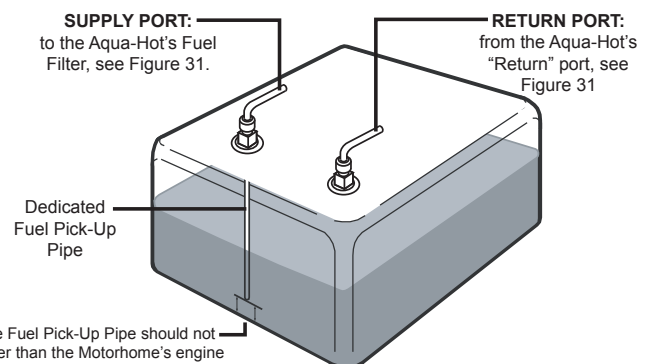

NOTE: The Fuel Pick-Up Pipe should not extend further than the Motorhome's engine fuel supply pick-up and should be consistent with the on-board Generator's fuel supply pick-up length.

Section 7: Fuel System

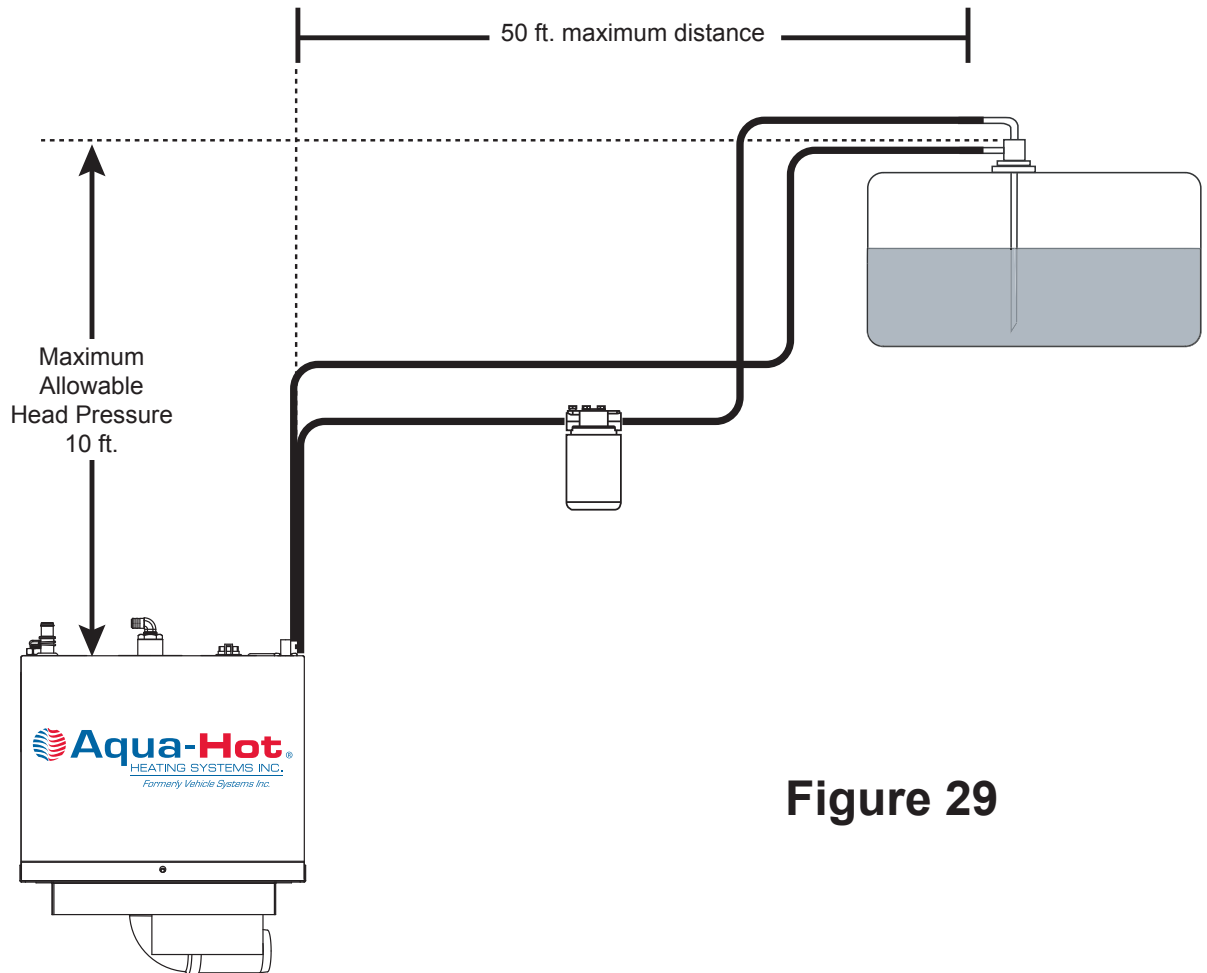
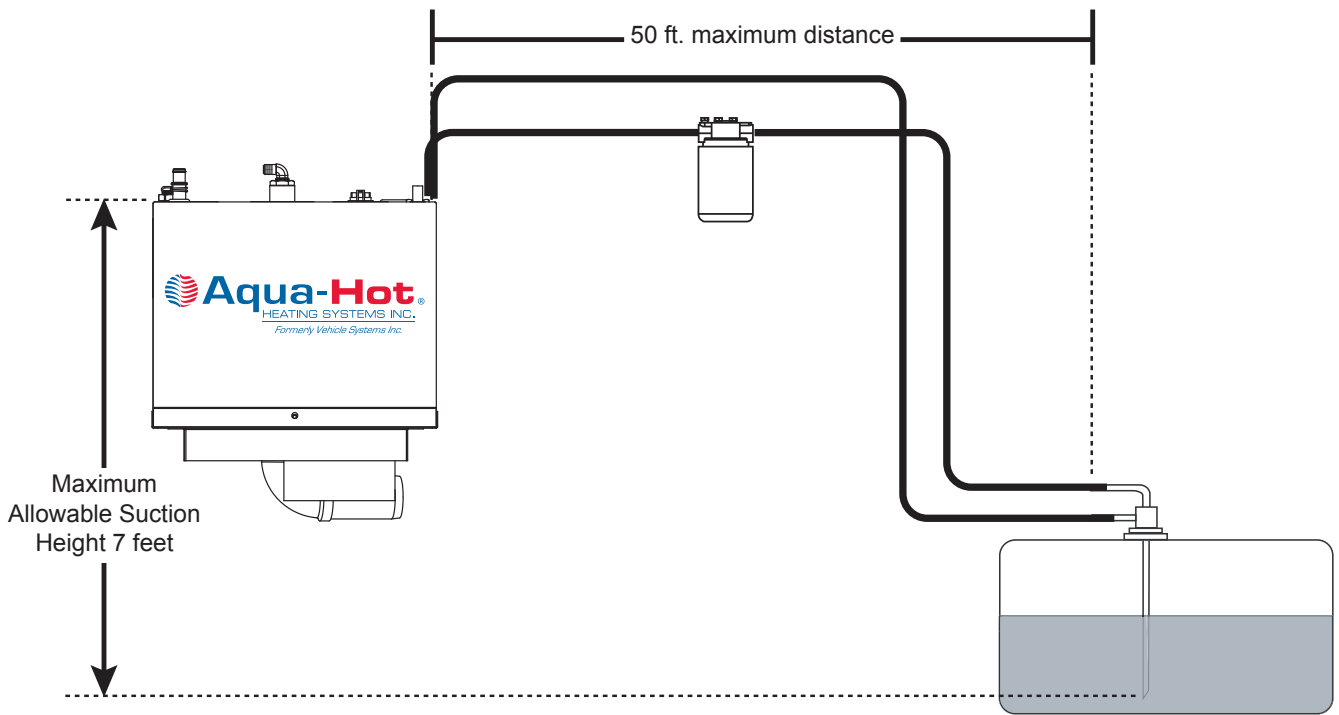

Figure 29

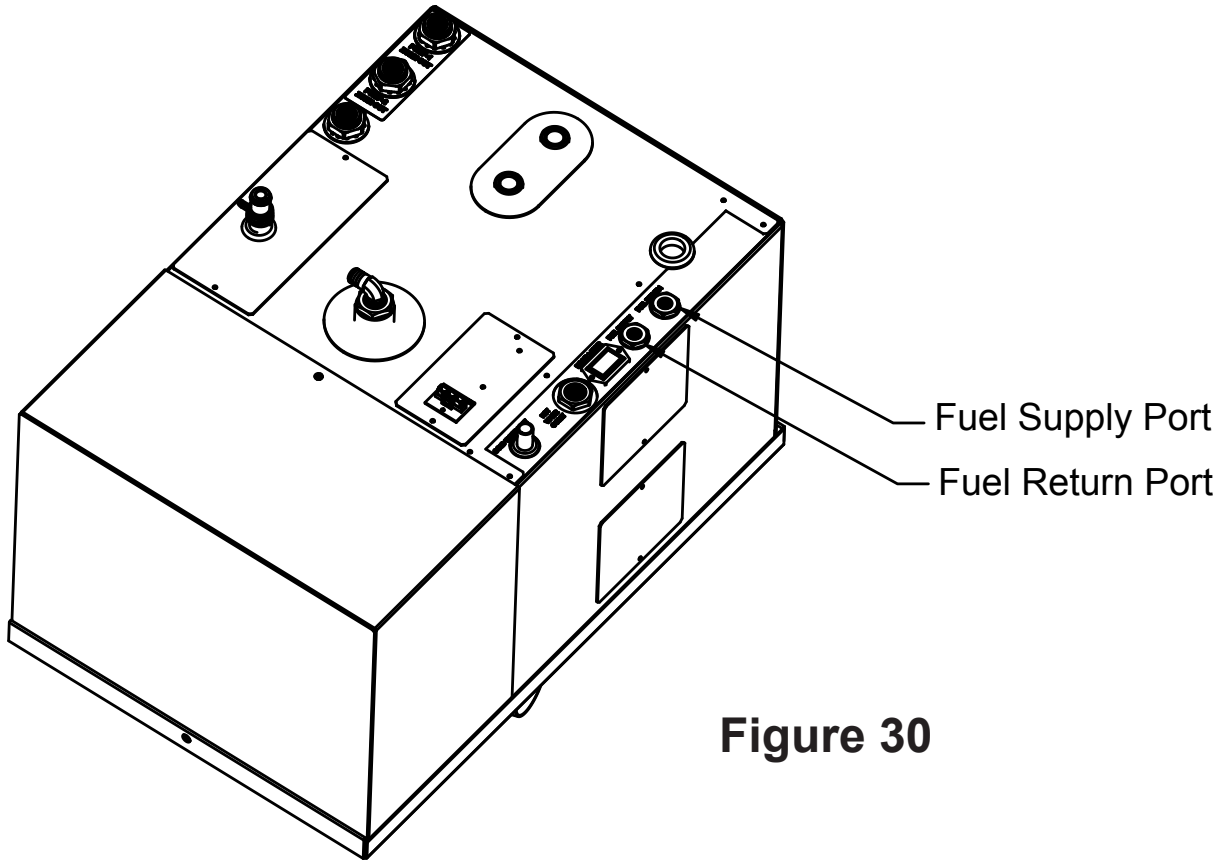

Figure 30

NOTE: Reference Figure 28 for details on the Fuel Tank connections. Reference Figure 30 for details on the Aqua-Hot's Fuel Port connections.

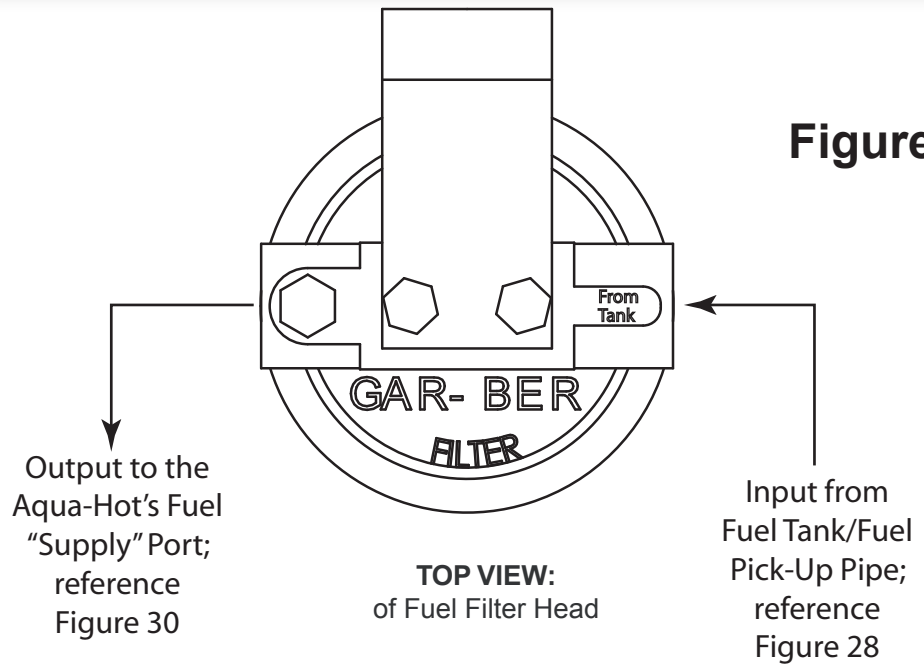
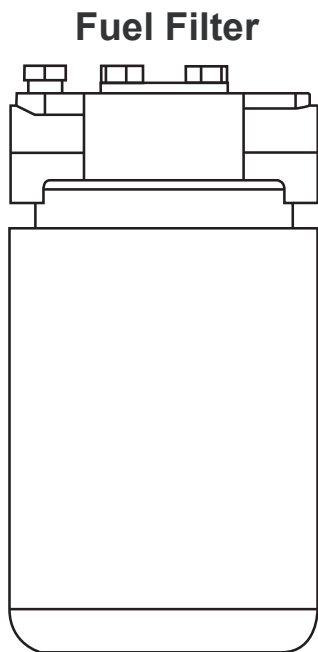

Figure 31

Section 8: Engine Preheat System

Location:

- The Supply and Return ports on the vehicle's engine should be kept as far apart as possible. This will ensure that the entire engine is thoroughly preheated; reference Figure 32.

NOTE: If assistance is needed in determining the best Supply and Return ports for a specific engine, please contact the particular Engine's manufacturer or chassis supplier.

The engine's coolant should be allowed to flow as freely as possible to maximize the Aqua-Hot's engine preheating system.

The engine's Return port is where the heated coolant is returned to the Engine Block from the Aqua-Hot. This port should be a high connection point on the Engine Block or a suction port on the engine's Water Pump; reference Figure 32.

The engine's Supply port is where the engine's coolant is supplied to the Aqua-Hot's Engine Preheat Circulation Pump. This port should be a low connection point on the Engine Block or a pressure outlet port on the Engine's Water Pump; reference Figure 32.

Ensure that the Engine Preheat Supply and Return hoses do not run too close to the Engine's Turbo Charger.

Plumbing Requirements:

- Use 3/4 in. I.D. (Inside Diameter) Plumbing Lines/Automotive type Heater-Hose for the Engine Preheating system.
- Lay both Engine Preheat Lines as flat as possible and avoid any extreme rises in height in order to eliminate the potential for air traps.
- Run both Plumbing Lines in areas where they cannot be pinched off or damaged during normal operating conditions.
- Secure both Plumbing Lines where necessary and apply protective shielding in areas where chafing may occur.

NOTE: Rubber Coated/Closed-Type Clamps are recommended when securing the Plumbing Lines.

- Use one-piece Engine Plumbing Fittings in order to reduce the potential for coolant leaks.

- It is recommended that Pipe Thread Sealant be used on all Engine Plumbing Fittings.

Installing the Plumbing:

1. Install both engine preheat Plumbing Lines and mark with Arrows and/or Labels at both ends.

NOTE: The labels should indicate whether the Plumbing Line is supplying coolant to the Aqua-Hot or whether it will be returning heated coolant to the vehicle's engine; reference Figures 1 and 33.

2. Drain the Engine's coolant.
3. Remove the selected Supply and Return port "Plugs" from the engine.

NOTE: Should one or both of the selected engine ports already have Plumbing Fittings attached to them, it may be necessary to "tee" into those existing Plumbing Fittings. Please contact Aqua-Hot Heating Systems, Inc.' Product Application Department at 1-800-685-4298 for additional assistance.

4. Install and tighten the Plumbing Fittings into the Supply and Return ports on the Vehicle's Engine.
5. Install and clamp both the Supply and Return engine Plumbing Lines/Automotive Type Heater Hoses to the Engine's Plumbing Fittings; reference Figure 32.
6. Install and tighten a Plumbing Fitting into the "Inlet" port on the Aqua-Hot's Engine Preheating System; reference Figures 1 and 33.

NOTE: It is recommended that two wrenches be used when tightening these Plumbing Fittings.

7. Attach and clamp the Engine's Supply Plumbing Line to the Aqua-Hot's "Inlet" connection; reference Figure 33.
8. Attach and clamp the Engine's Return Plumbing Line to the Aqua-Hot's "Outlet" connection; reference Figure 33.
9. Verify that all fittings and connections have been tightened, then refill the Engine's Coolant System.

Section 8: Engine Preheat System

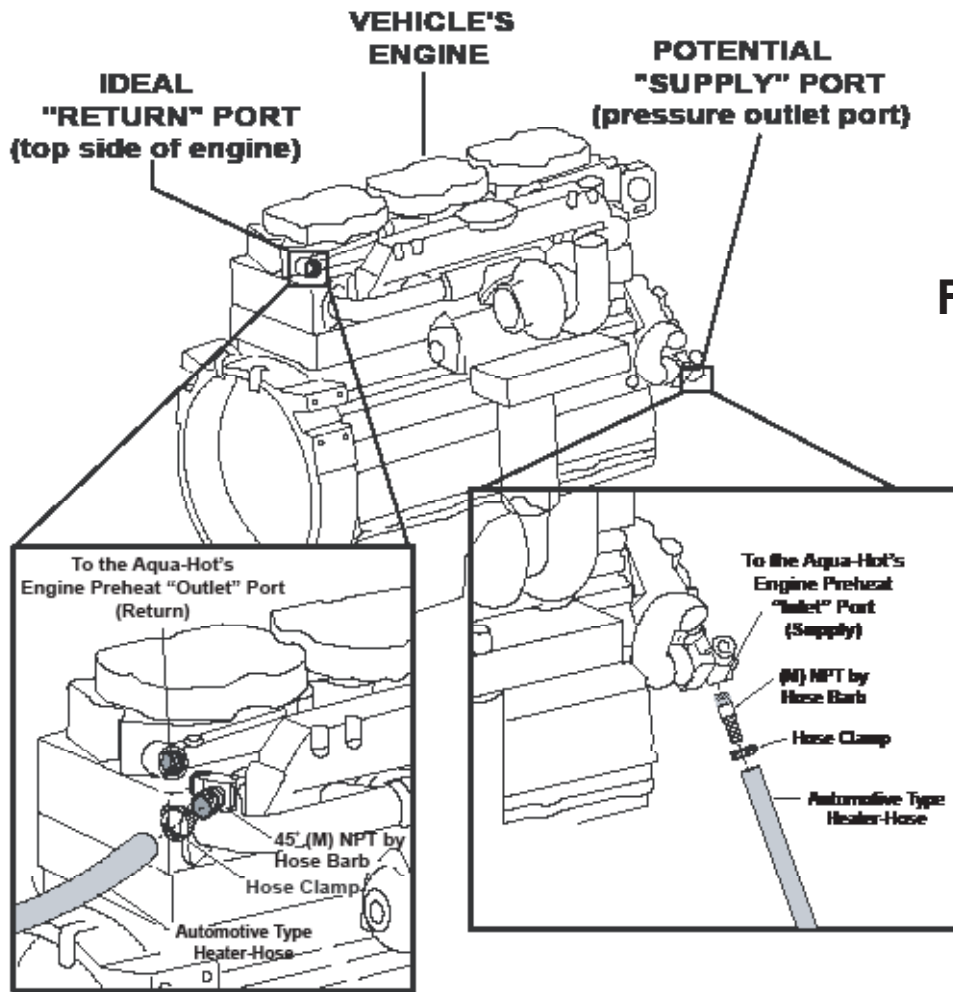

Figure 32

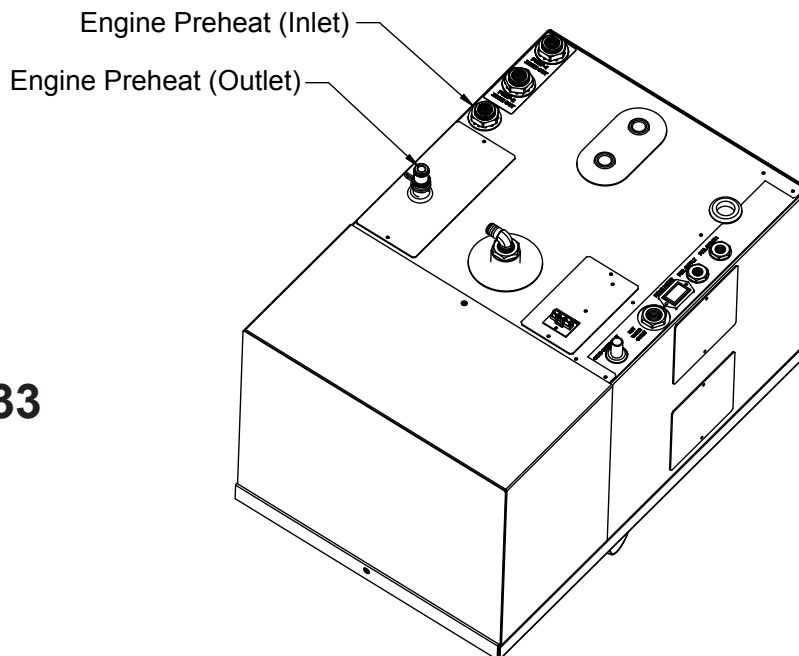

Figure 33

Section 9: Exhaust System

WARNING!

The Aqua-Hot's exhaust is hot and must be kept away from any heat-sensitive material. **DO NOT** direct exhaust downward as a fire may result when parked in dry, grassy areas. In addition, the exhaust must not terminate beneath the vehicle or beneath an openable window or vent. Refer to "Internal Combustion Engine Exhausts and Vehicle Wall Openings" in RVIA's ANSI/NFPA 1192 Handbook for the Recreational Vehicle Standards, as well as the National Fire Protection Association's (NFPA) 1192 Standard on Recreational Vehicles for additional information.

CAUTION:

The Exhaust System **MUST NOT** terminate beneath the vehicle. Failure to conform could create a hazardous situation and will void the Aqua-Hot's ETL product listing.

DO NOT terminate the Exhaust Pipe within the awning area of the Motorhome, if applicable. Be sure to keep the exhaust away from the slideout areas. Refer to the "Internal Combustion Engine Exhausts and Vehicle Wall Openings" in RVIA's ANSI/NFPA 1192 Recreational Vehicle Standards Handbook, as well as the National Fire Protection Association's (NFPA) 1192 Standard on Recreational Vehicles, for additional information.

All Aqua-Hot Exhaust System Installations **MUST** utilize the two Black Pipe Nipples and the Black Pipe Elbow, which are provided with the Heating System, in the configuration best suited for the particular Recreational Vehicle application. Failure to conform could create a hazardous situation and will void the Aqua-Hot's ETL product listing.

Exhaust System Requirements:

- The exhaust must be able to freely exit away from the vehicle without any obstructions.
- Angle the Exhaust Pipe towards the rear of the vehicle so that the exhaust fumes will naturally move away while the vehicle is in motion.
- Use standard 2.0 inch Automotive Type Exhaust piping and avoid bends, if possible.
- A maximum of two 90° Exhaust Pipe bends is allowed.

- Do not use galvanized pipe or fittings; only Black Iron Pipe and fittings should be used.
- The total length of Exhaust Pipe should not exceed 20 feet.
- The Aqua-Hot is supplied with a 3-inch and a 4-inch Black-Pipe Nipple (1.5 inch diameter) along with a 1.5 inch Exhaust Elbow. These three Exhaust System Components **MUST BE** utilized with all product installations. Be sure to reference Figure 36 to determine which Exhaust Nipple should be connected directly to the Aqua-Hot's Exhaust Port (i.e., the 3 inch or the 4 inch Black Pipe Nipple).

NOTE: Should your particular application require more than 20 feet of Exhaust Pipe, please contact Aqua-Hot Heating Systems, Inc. Product Application Department at 1-800-685-4298 for assistance.

Installing the Exhaust System:

1. Run the Exhaust Pipe to the driver's side of the vehicle and ensure that the exhaust fumes cannot enter into the passenger compartment. Be sure to keep the exhaust away from the slide out areas.
2. Be sure to secure the end of the Exhaust Pipe to the vehicle with the proper Exhaust Hanger/ support hardware.

WARNING!

DO NOT run exhaust pipe under Propane Tank Pressure Relief Valve through area of the Diesel-Burner fresh air intake. Also, **DO NOT** terminate the Exhaust Pipe within the awning area of the Motor Home, if applicable. Be sure to keep the exhaust away from the slide out areas. Reference Section 3-4.3 in the RVIA "Handbook for Recreational Vehicle Standards" for additional information.

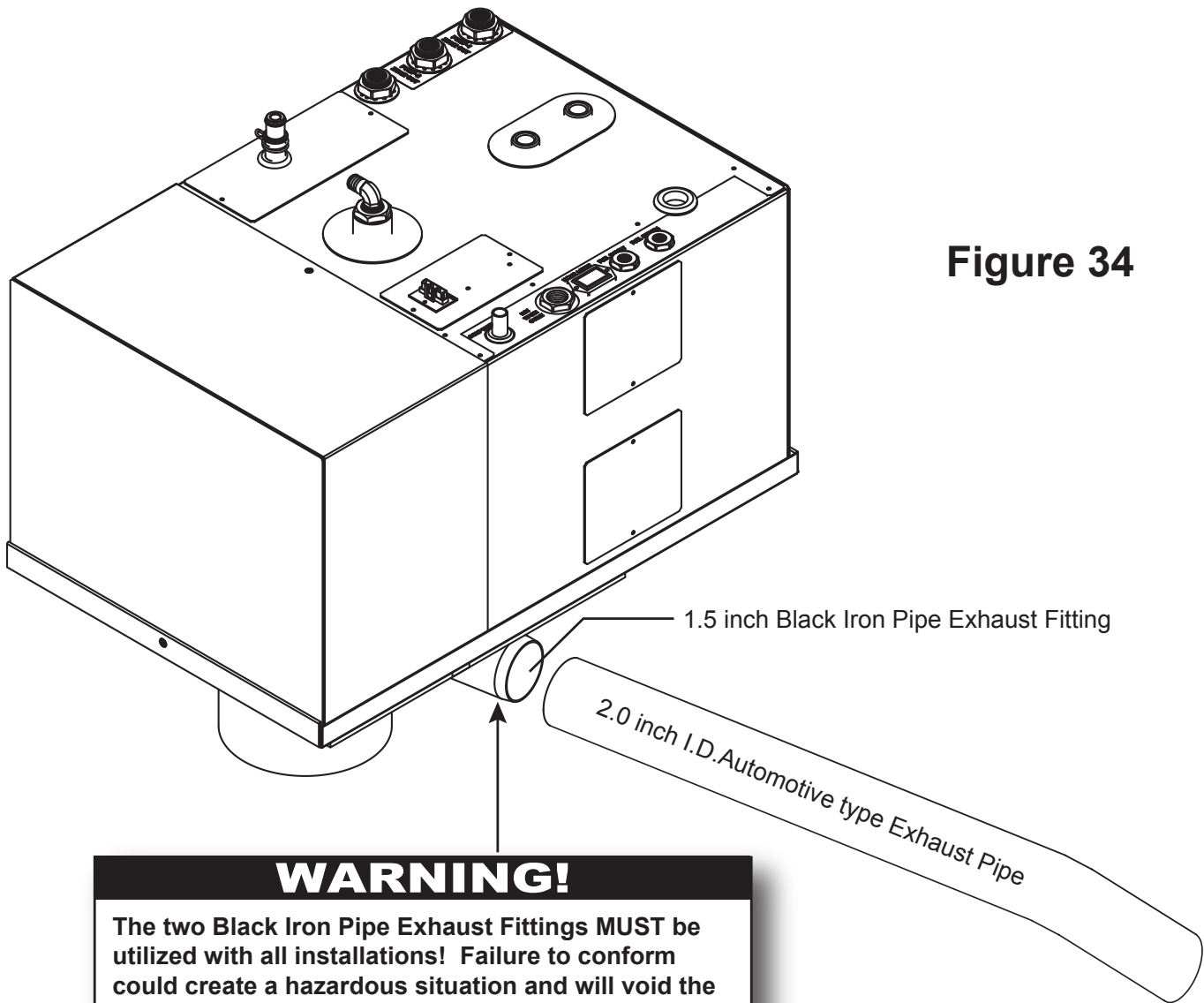

Figure 34

WARNING!
The two Black Iron Pipe Exhaust Fittings **MUST** be utilized with all installations! Failure to conform could create a hazardous situation and will void the Aqua-Hot's ETL product listing.

NOTE: A maximum of two 90° bends is allowed in the Exhaust Pipe. Also, the Exhaust Pipe cannot be longer than 20 feet.

Figure 35

NOTE: The Exhaust Elbow can be rotated 270° as shown in the illustration; however, the Exhaust must not terminate beneath the vehicle, beneath an openable window or vent, or through the area of the Diesel-Burner air inlet. Reference Section 9 of this manual for Exhaust System requirements.

Front of Hydro-Hot

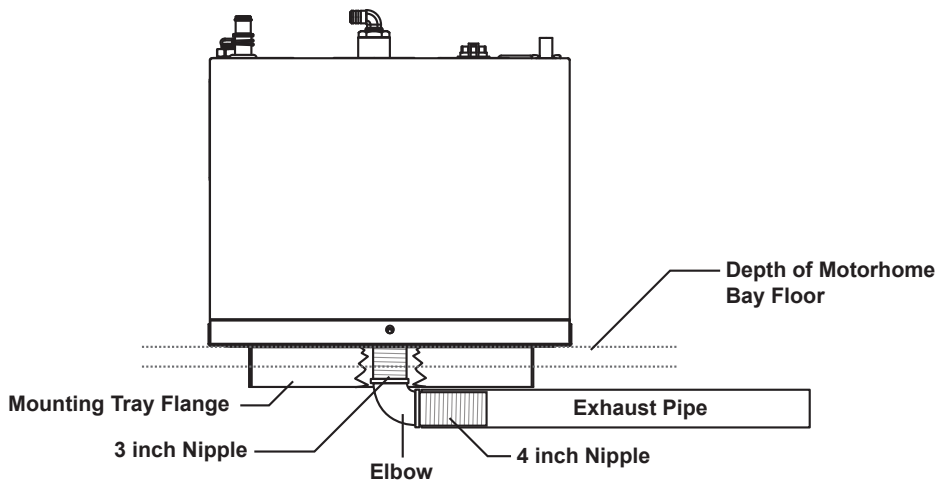
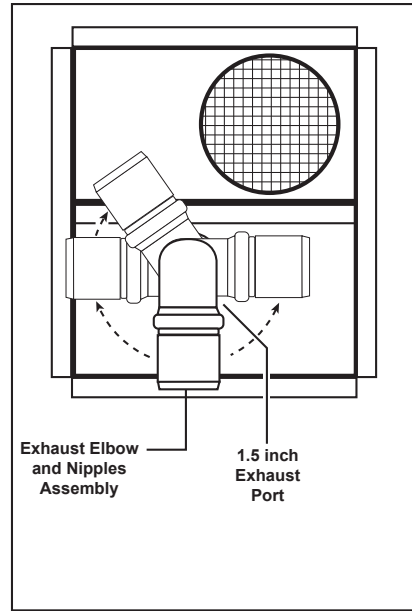
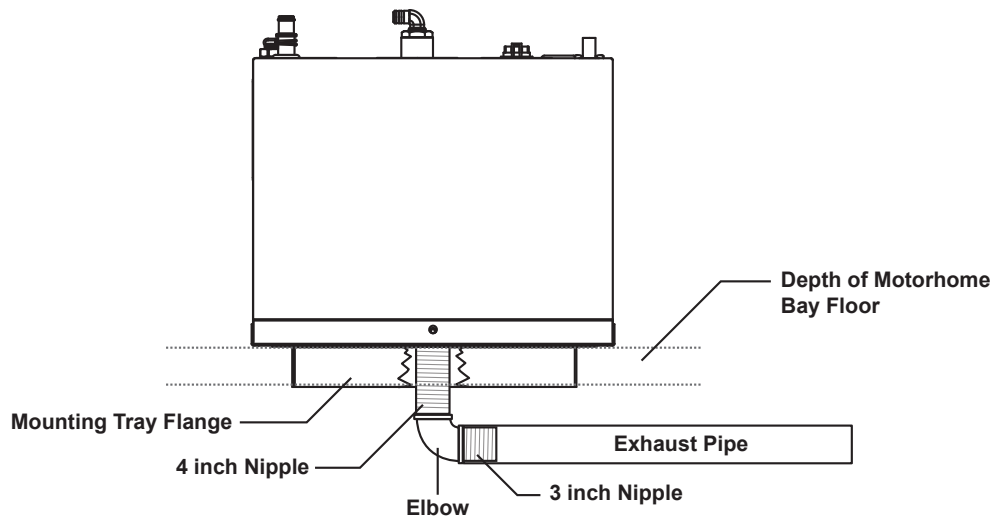

Figure 36



Section 10: Electric Wiring

Electronic Controller Wiring:

NOTE: Please reference Appendix A for specific wiring information.

- All Electronic Controller Thermostat and Switch connections (excluding two) illustrate an “(I)” or an “(O)” symbol. The “(O)” symbol indicates a positive 12 Volt-DC **output** to a particular Thermostat or Switch, while the “(I)” symbol indicates a positive 12 Volt-DC **input** signal from a particular Thermostat or Switch. The 12 Volt-DC **output** signal is always present as long as the Electronic Controller is powered by a 12 Volt-DC Power Source, while the 12 Volt-DC **input** signal is only present whenever a Switch is activated or whenever a Thermostat is “calling for heat”; reference Appendix A.
- All Electronic Controller Fan power connections (and two Switch connections) illustrate a “(+)” or a “(-)” symbol which indicates that they are Polarity Sensitive. Therefore, be sure to use care when wiring these particular components to the Electronic Controller.
- Each heating zone “FAN” circuit can supply up to 2.0 Amps of Direct Current. This 12 Volt-DC power source allows for multiple Cozy III Heat Exchangers to be wired “in-parallel” (e.g., Heating Zone 1, etc.); reference Figure 18 and Appendix A.

NOTE: A maximum power consumption of 24 Watts can be supplied by the Electronic Controller for each “FAN” Heating Zone.

- Heating Zone 1 is reserved electrically for the “Living Room/Kitchen Heating Zone” (Heating Loop 1) **ONLY**, and Heating Zones 2, 3, and 4 are reserved electrically for the “Bathroom, Fresh Water Tank, and Bedroom Heating Zone” (Heating Loop 2) **ONLY**.

NOTE: Heating Zone 5 is reserved electrically for the “Optional Heating Zone” (Heating Loop 1) **ONLY**.

- All Switch connections are to be wired directly to the Aqua-Hot’s “Switch Panel Connections”; reference Figures 26 and 27 and Appendix A. Both the “IND-LT (+) B3” and the “IND-LT(-) B6” connection are reserved electrically **ONLY** for the “Diesel” Switch Indicator Light connections.
- The Aqua-Hot’s Electronic Controller is designed to work with most Electronic Room Thermostats; however, the chosen Thermostat must produce a constant 12 Volt-DC output signal and must receive its 12 Volt-DC Power Supply from

the Electronic Controller (i.e., “THERM-O”) in order to ensure that the Thermostat and Electronic Controller are properly **fuse protected**.

NOTE: It is recommended that the wire numbers in Appendix A be used when installing the Aqua-Hot, in order to assist with differentiating between the separate heating zones and to aid Service Personnel with troubleshooting.

CAUTION:

DO NOT activate the Diesel-Burner until the antifreeze and water heating solution has been added to the Boiler Tank and the Heating System has been completely bled of air. Operating the Aqua-Hot without the antifreeze and water heating solution will cause serious damage to the Aqua-Hot’s Boiler Tank.

DO NOT connect the 12 Volt-DC Power to the Aqua-Hot if the vehicle requires welding. Electrical welding will cause serious damage to the Diesel-Burner’s Controller and the Aqua-Hot’s Electronic Controller.

Reference Appendix B for proper power wire gauge sizing. Please note that under full load conditions, the Aqua-Hot can draw as much as 22 Amps of DC current.

Because the Aqua-Hot is designed to shut down in the event that the VDC Voltage Level drops too low to properly operate, it is imperative that the proper wire gauge be determined and utilized.

Be sure to protect against accidental shorting (i.e., chassis shorting) by incorporating a 25-Amp rated In-Line Fuse into the Power wire at the Battery location; reference Figure 37.

All Electric Installations, Systems, and Equipment shall comply with Article 551, Parts I and III through VI of NFPA 70.

NOTE: It is recommended that the wire numbers in Appendix A be used when installing the Aqua-Hot in order to assist with differentiating between the separate Heating Zones and to aid Service Personnel with troubleshooting.

Diesel-Burner Controller Wiring:

NOTE: Please reference Appendix A for electrical wiring information.

Section 10: Electric Wiring

The Diesel-Burner Controller requires a 12 Volt-DC power supply. Therefore, as illustrated in Appendix A, it is recommended that the Diesel-Burner Controller's Power and Ground wires be connected directly to the Aqua-Hot's Electronic Controller "JP5" (Positive/Power connection) and "GND" (Negative/Ground connection) Battery connection, respectively. This electrical wiring arrangement will ensure that these particular power wires are "fuse protected" against a potential electrical short (i.e., chassis short).

Connecting the 12 Volt-DC Power:

1. Locate the Diesel-Burner Controller's Power and Ground wires within the Aqua-Hot's "JP4" Electrical Wiring Harness; reference Appendix A and C2 .

NOTE: The black, negative wire is designated as wire "18," and the red, positive wire is designated as wire number "19."

2. Run both Diesel-Burner Controller wires to the chosen mounting location of the Aqua-Hot's Electronic Controller. The black, negative wire "18" connects to JP10 and the red, positive wire "19" connects to JP9 on the Electronic Controller; reference Appendix C2.
3. Run and connect two wires - one Red (+) wire and one Black (-) wire (Power and Ground), from the vehicle's battery to the Aqua-Hot's Electronic Controller Mounting Location; reference Appendix A and Figure 37. Reference Appendix B1 for appropriate wire gauge.

NOTE: The optional battery disconnect option is explained on page C1. If the optional Secondary 12 Volt-DC Battery Connection on the Aqua-Hot's Electronic Controller is used, run a second Red (+) wire from the vehicle's **House Battery Disconnect** to the Electronic Controller's Mounting Location; reference Figure 37, Appendix A, and Appendix C1.

NOTE: The Aqua-Hot's Electronic Controller must be reset anytime VDC Power is disconnected and then reconnected to the heater. The Electronic Controller can be reset either by pressing the "Low Voltage Reset" button located on the Electronic Controller (use a thin, straight, nonmetallic object to access the reset button through the small hole in the faceplate) or by turning **OFF** the "Diesel" switch on the Heater's Interior Switch Panel for approximately 30 seconds, then turning the switch back **ON**. Reference Figure 38 for the location of the "Low Voltage Reset" button on the Electronic Controller.

Section 10: Electric Wiring

Figure 37

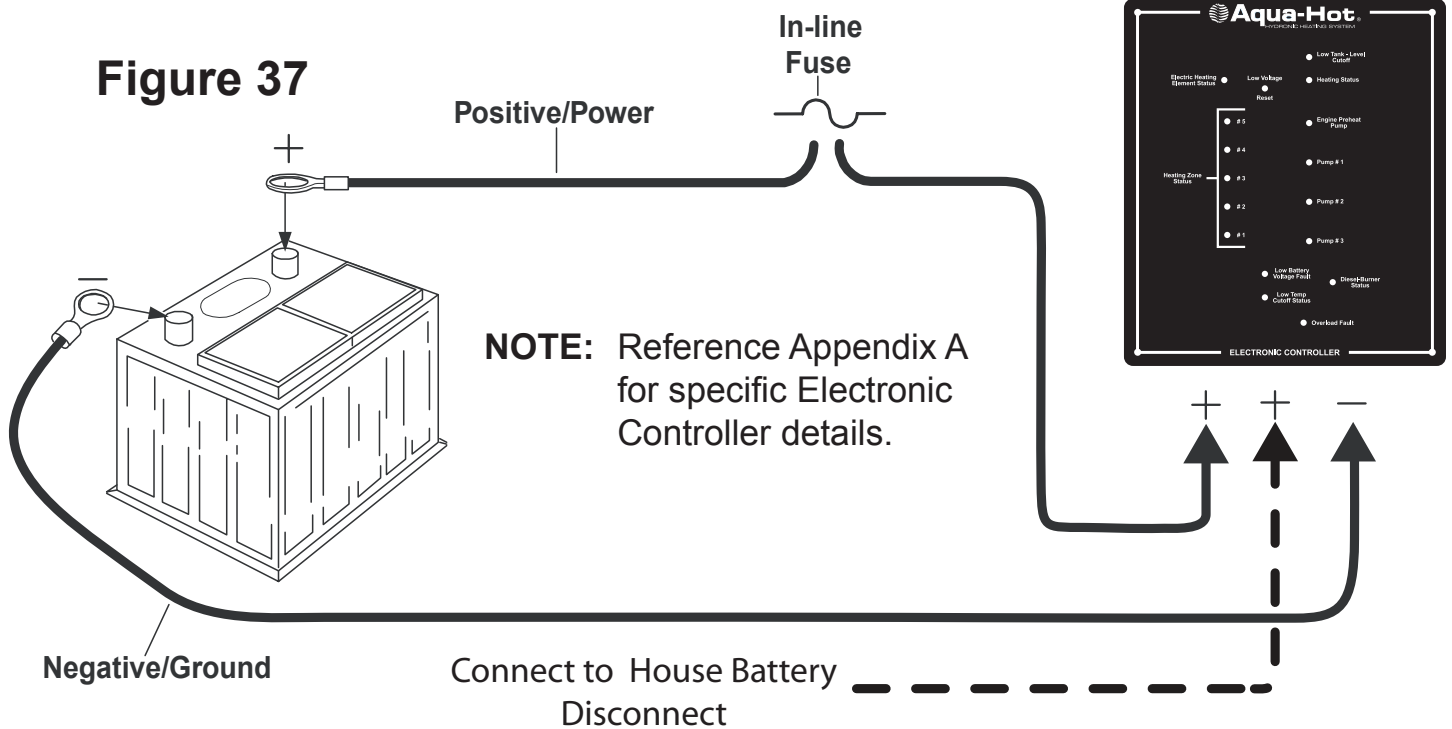

NOTE: If connecting the optional wire, jumper connecting terminals on Electronic Controller must be removed.

Figure 38

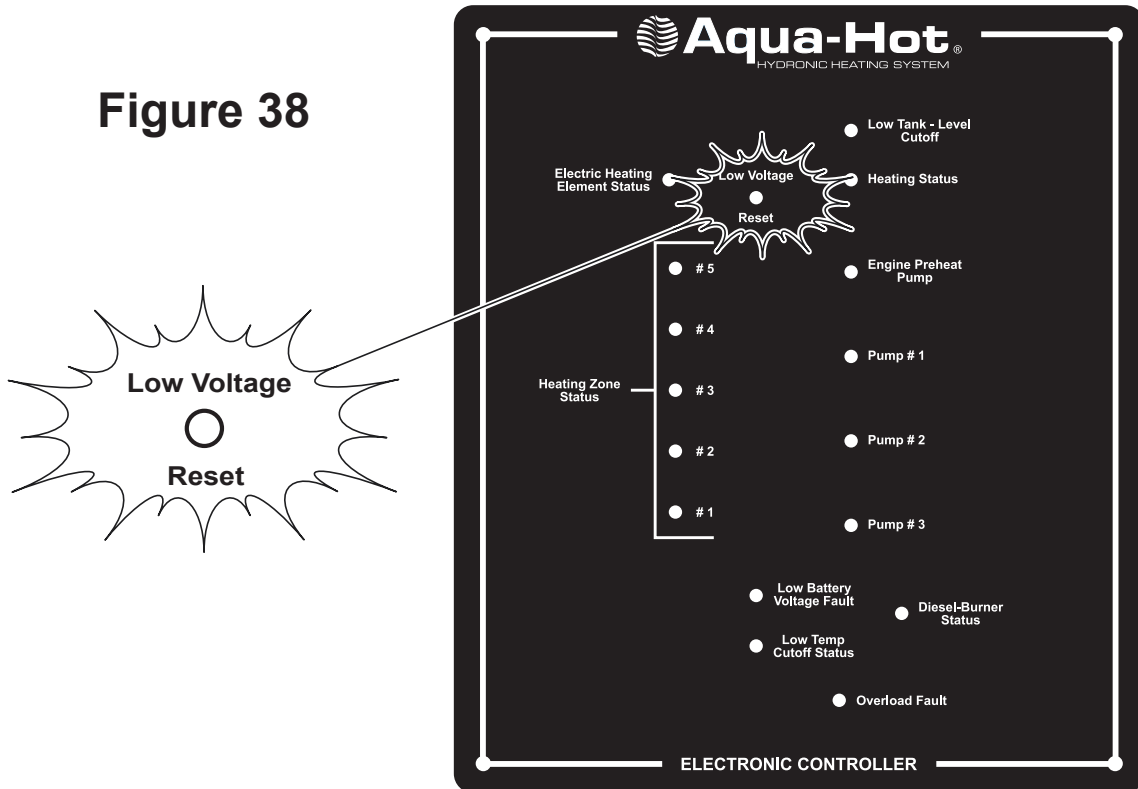

Section 10: Electric Wiring

CAUTION:

All Electric Installations, Systems, and Equipment shall comply with Article 551, Parts I and III through VI of NFPA 70, as well as the regulation of authorities having jurisdiction and CSA Standard B139.

DO NOT activate the Aqua-Hot's Electric Heating Element until the antifreeze and water heating solution has been added to the Aqua-Hot's Boiler Tank and the heating system has been completely bled of air. Operating the Aqua-Hot without the antifreeze and water heating solution will cause serious damage to the Aqua-Hot's Boiler Tank.

If the wires are not fully displaced, but they are all properly aligned, squeeze the connector over each wire contact location until the wires are fully displaced and the bow in the clear cover is gone.

Connecting the 120 Volt-AC Power:

1. Remove one inch of the exterior sheathing from the end of the ROMEX Cable; reference Figure 40.

NOTE: DO NOT remove the insulation from each individual wire in the ROMEX Cable; this insulation must remain intact.

2. Pre-form the wires in the ROMEX Cable in preparation for their insertion into the locator slots; reference Figure 40.
3. Hold the clear cover with the bottom facing upward; reference Figure 41.
4. Lay each wire into its corresponding locator slot; reference Figure 41.
5. While holding the clear cover, take the opposite piece of the connector (the Housing) and position the hinge posts into the hinge slots and push down until both posts lock into place; reference Figure 42.
6. Close the clear cover and the Housing together as much as possible by hand; reference Figure 43. Then, with pliers, grip the clear cover and the housing on one side by the locking latch. Squeeze the pliers handle until the locking latch snaps over the ramp into the locked position; reference Figure 44. Repeat this process for the other side of the connector.
7. Look through the clear cover and make a thorough inspection of the finished connector in order to determine if correct wire displacement has occurred.

NOTE: Correctly placed wires will be fully displaced in their correct wire location slots without significantly bowing the clear cover. (A significant bow in the clear cover would indicate that the wires are not fully displaced or that the wires are misaligned.)

Section 10: Electric Wiring

Installing the AC Strain Relief Bracket:

1. Once the 120 Volt-AC power wires have been installed into the AC Power Connector Plug, secure the AC Power Connector Plug with the clear cover facing outward to the AC Strain Relief Bracket with the included screws and washers; reference Figure 39 A.
2. Tighten the screws securely with a Phillips head screwdriver, being careful not to crack the AC Power Connector Plug's clear cover.
3. Insert the AC Power Connector Plug into the AC Power Receptacle until it snaps into place; reference Figure 39 B.
4. Be sure the Nylatch Grommet is lined up with the 5/16 inch hole in the AC Relay Access Panel. Press down on the Nylatch Plunger until it snaps into place in order to secure the AC Strain Relief Bracket to the AC Relay Access Cover; reference Figure 39 C.

5. Place the AC Power Connector Plug's Romex Cable lengthwise down the AC Strain Relief Bracket, centered between the two sets of holes; reference Figure 39 D.
6. Using the first set of holes, secure the AC Power Connector Plug's Romex Cable to the AC Strain Relief Bracket with a cable tie; reference Figure 39 D.
7. Using the second set of holes, secure the AC Power Connector Plug's Romex Cable to the AC Strain Relief Bracket with a second cable tie; reference Figure 39 D.

NOTE: The AC Power Cable will require a bend from the AC Power Connector Plug to the securing cable ties in order to comply with NEC (National Electric Code) 2005 Code 334.24, which states, "The radius of the curve of the inner edge of any bend during or after installation shall not be less than five times the diameter of the cable."

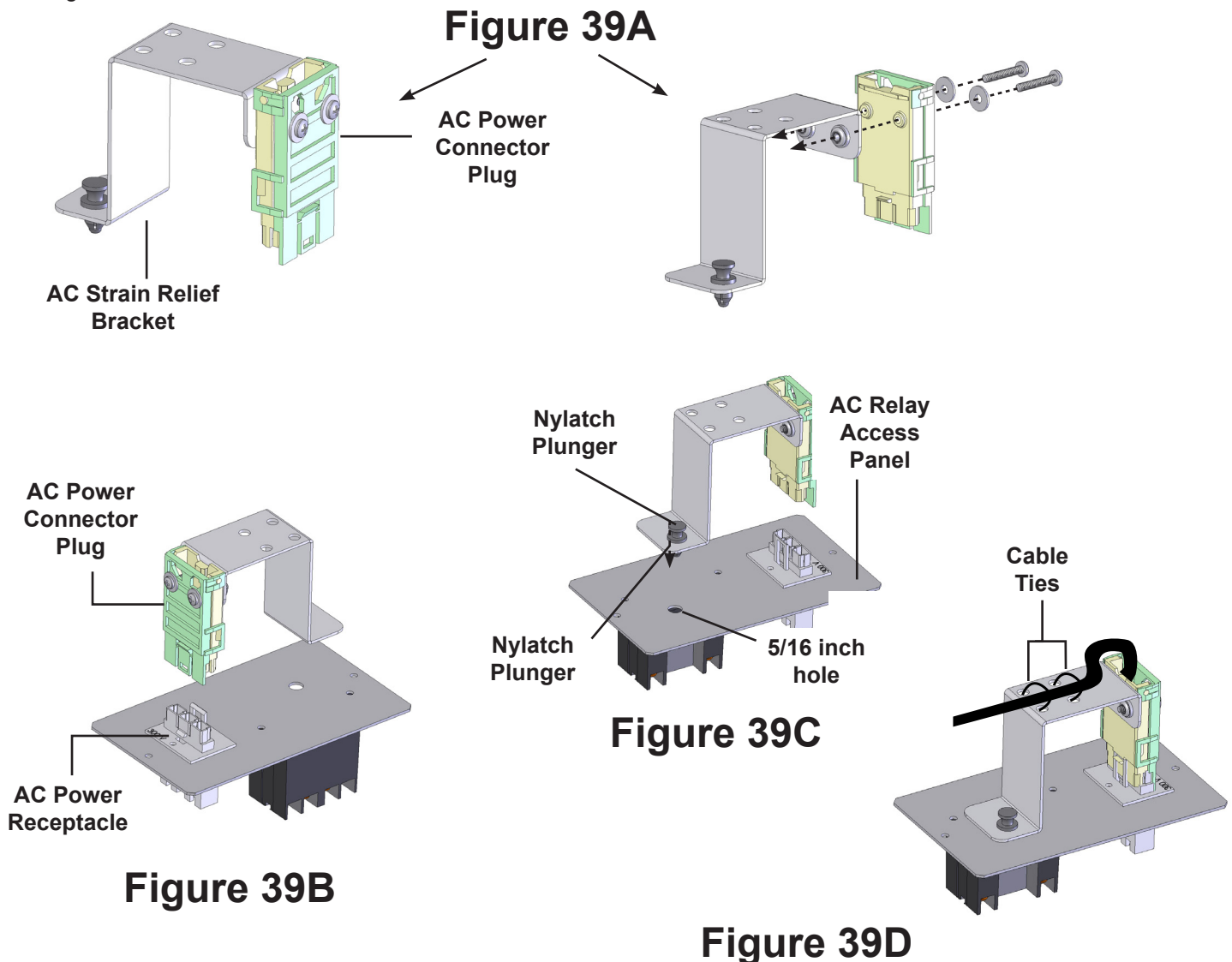

Figure 40

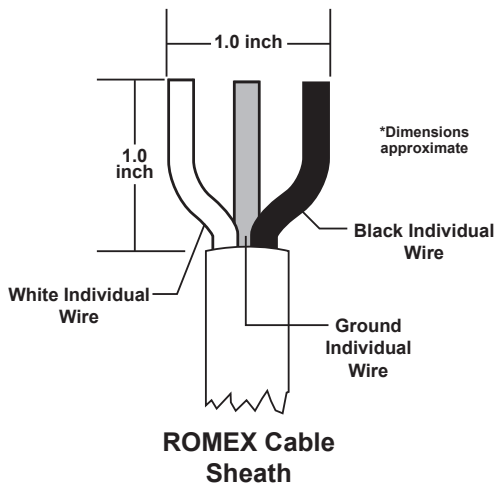

Figure 41

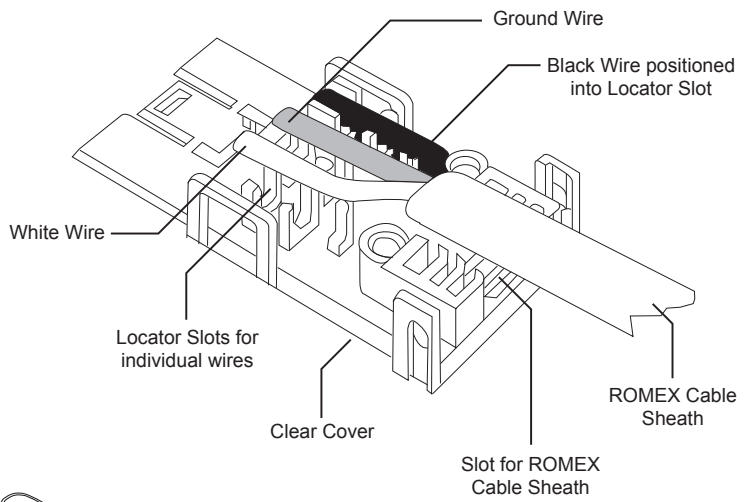

Figure 42

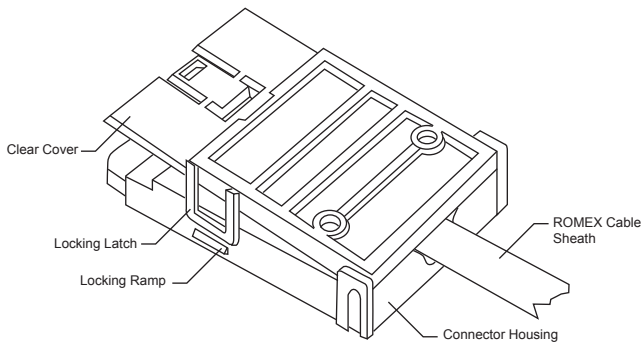
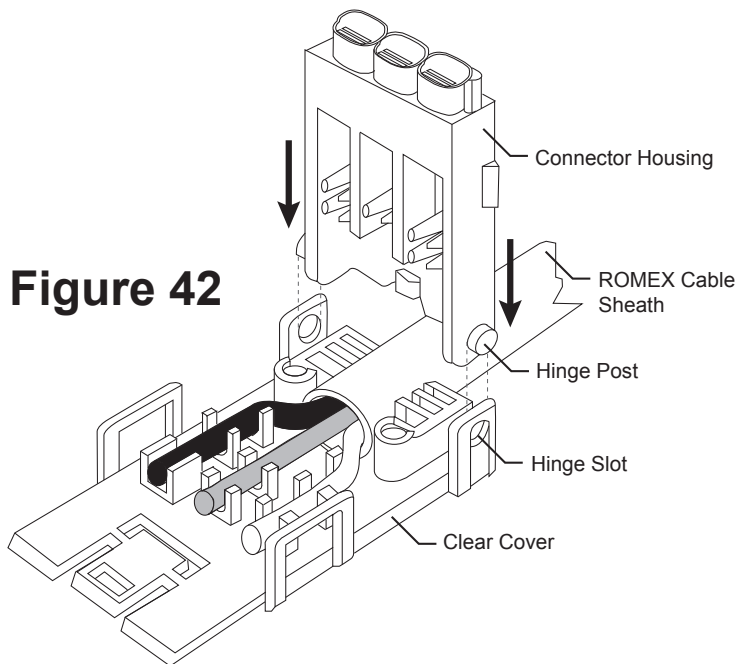
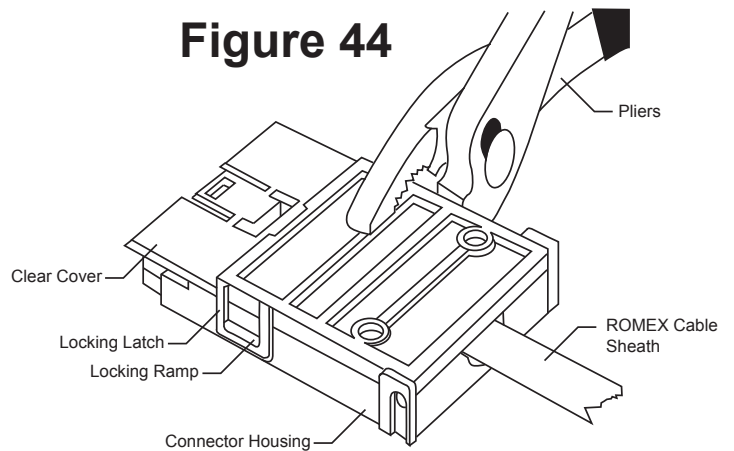

Figure 43

Figure 44



Section 11: Purging the Systems

WARNING!

Only propylene glycol based “boiler” type antifreeze deemed “GRAS” (Generally Recognized as Safe) by the FDA shall be used in the Aqua-Hot’s Hydronic Heating System. Failure to use the above-specified antifreeze type could result in serious injury or death.

Hydronic Heating System

Purging the Hydronic Heating System:

CAUTION:

Ensure that the Overflow Tube is connected from the Aqua-Hot’s Expansion Tank Connection to the Expansion Tank’s bottom connection and from the Expansion Tank’s top connection through the Overflow Tube Hole in the Motorhome’s Bay floor prior to beginning this antifreeze and water heating solution fill procedure. Failure to do so could result in an antifreeze spill in the motorhome’s bay. Reference Figure 8.

NOTE: In order to provide the best freeze protection, boil-over protection, and anti-corrosion and rust protection, a 50/50 mixture ratio of “GRAS” approved propylene glycol antifreeze and water is recommended.

Reference Appendix D for additional information regarding the antifreeze and water heating solution.

Be sure to use a “GRAS” boiler-type propylene glycol based antifreeze rather than an RV and Marine antifreeze or an Automotive antifreeze/coolant. If assistance is needed in selecting an appropriate antifreeze, please contact the Aqua-Hot Heating Systems, Inc. Product Application Department at 1-800-685-4298.

1. Open the Aqua-Hot’s drain valve located at the front of the heater; reference Figure 45.
2. Connect a piece of 1/2 inch PEX tubing (this piece should be long enough to be used to transport the antifreeze and water heating solution from its source to the Aqua-Hot) to the drain valve.
3. Fill the Aqua-Hot completely with the antifreeze and water heating solution. (This will take approximately 5 gallons; look for the solution to enter the overflow tube attached to the Expansion Tank Connection on top of the Aqua-Hot.)
4. Close the drain valve.

NOTE: You can choose either procedure A or procedure B. At this point, it will be necessary to select either the “Bypassing the Thermostat through the Aqua-Hot’s Electronic Controller” procedure or the “Bypassing the Thermostat by Grounding the Circulation Pump” procedure contained in this section in order to purge the Hydronic Heating System. Either procedure will allow the Circulation Pumps to operate without first heating the antifreeze and water heating solution.

A. Bypassing the Thermostat through the Aqua-Hot’s Electronic Controller:

- i. Ensure that all switches on the Heater’s Interior Switch Panel are in the “OFF” position and that the Boiler Tank has been filled with the appropriate antifreeze and water heating solution.
- ii. Locate the Aqua-Hot’s Electronic Controller and remove the four (4) screws, which secure the Electronic Controller’s Faceplate to the Mounting Bracket. Set the Faceplate aside in a location where it will be protected from possible scratches.
- iii. Reference Figure 46 for the location of the “J4 AH TANK SEN” Jumper Pins, then locate these Jumper Pins on the Electronic Controller.
- iv. Gently pull the black Jumper Cap off of the “J4 AH TANK SEN” Jumper Pins.
- v. Place the black Jumper Cap over both Jumper Pins and press the cap down to set the cap properly in place.
- vi. Verify **Low Temp. Cutoff Light** is **ON**.
- vii. Switch **ON** any Interior Zone Thermostat to its maximum temperature setting.
- viii. Leave the Interior Zone Thermostat **ON** for approximately 1-3 minutes. This will activate the corresponding Circulation Pump, allowing it to purge one of the Aqua-Hot’s Heating Loops. Then, switch the Thermostat **OFF**.
- ix. Open the drain valve and completely fill the Aqua-Hot’s Boiler Tank with additional antifreeze and water heating solution.
- x. Repeat steps vii and viii for both Heating Loops until all air has been completely bled from the entire heating system.

Section 11: Purging the Systems

NOTE: All air is bled from the Heating System when both "Return Plumbing Lines" are free of air; reference Figure 18.

- xi. Close the drain valve.
- xii. Remove the PEX tubing from the drain valve.
- xiii. Check the Aqua-Hot's Expansion Tank and top off, if necessary.

NOTE: Be sure to fill the Expansion Tank to the "COLD" level with the antifreeze and water heating solution.

- xiv. Once the Hydronic Heating System has been purged, remove the black Jumper Cap from the two pins on "J4 AH TANK SEN" and place it over the single left pin; reference Figure 46.
- xv. You may now proceed to the Engine Preheat section.

B. Bypassing the Thermostat by Grounding the Zone Circulation Pumps:

- i. Verify the Electronic Controller has been connected to a 12 VDC power source.
- ii. Ensure that the Boiler Tank has been filled with the appropriate antifreeze and water heating solution.
- iii. Locate the Heating Zone Circulation Pumps; reference Figures 1 and 47.
- iv. Take the Circulation Pump's Blue (negative) wire (wire #37 for Circulation Pump #1 or wire #35 for Circulation Pump #2; reference Appendix A) and disconnect it from the connector of the opposing wire.
- v. Connect an alligator clip to the spade terminal on the Circulation Pump's Blue (negative) wire and clip the opposite end of the cable to a ground source.

NOTE: The Circulation Pump will activate as soon as the pump is connected to a ground source; therefore, disconnect the alligator clip from the ground source during the antifreeze and water heating solution filling procedure.

- vi. Allow the Circulation Pump to operate for approximately 1-3 minutes in order to purge the corresponding Heating Loop, then remove the alligator clip from the ground source.
- vii. Open the drain valve and completely fill the Aqua-Hot's Boiler Tank with additional antifreeze and water heating solution.

- viii. Repeat steps v and vi for both Heating Loops until all air has been completely bled from the entire Heating System.

NOTE: All air is bled from the Heating System when both "Return Plumbing Lines" are free of air; reference Figure 18.

- ix. Once the systems have been purged, disconnect the alligator clips from the ground source and the Circulation Pump's wires. Then, reconnect the pump's wires as originally configured.
- x. Check the Aqua-Hot's Expansion Tank and top off, if necessary.

NOTE: Be sure to fill the Expansion Tank to the "COLD" level with the antifreeze and water heating solution.

NOTE: Ensure that each Circulation Pump's wiring has been returned to its original configuration; reference Figure 47.

Engine Preheat System

CAUTION:

Ensure that the Engine's Coolant System has been completely refilled prior to purging the Engine Preheat System.

Purging the Engine Preheat System:

1. Start and run the vehicle's engine until it reaches normal operating temperature in order to ensure that all air has been bled from the engine's coolant system. During this procedure, check for leaks in the Engine Preheat Plumbing system and connections.
2. Turn the engine **OFF**.
3. Check the engine coolant level and top off, if necessary.

Domestic Water System

CAUTION:

Verify that the Domestic Water Tank contains fresh water prior to bleeding the Fresh Water System.

Purging the Domestic Water System:

1. Ensure that the vehicle's Domestic Water Pump has 12 Volt-DC power, then activate it by opening each hot water faucet, one at a time, and running the water until all air is purged from the Domestic Water System.
2. Once the Domestic Water System is completely bled, check for leaks in the Domestic Water System.

Section 11: Purging the Systems

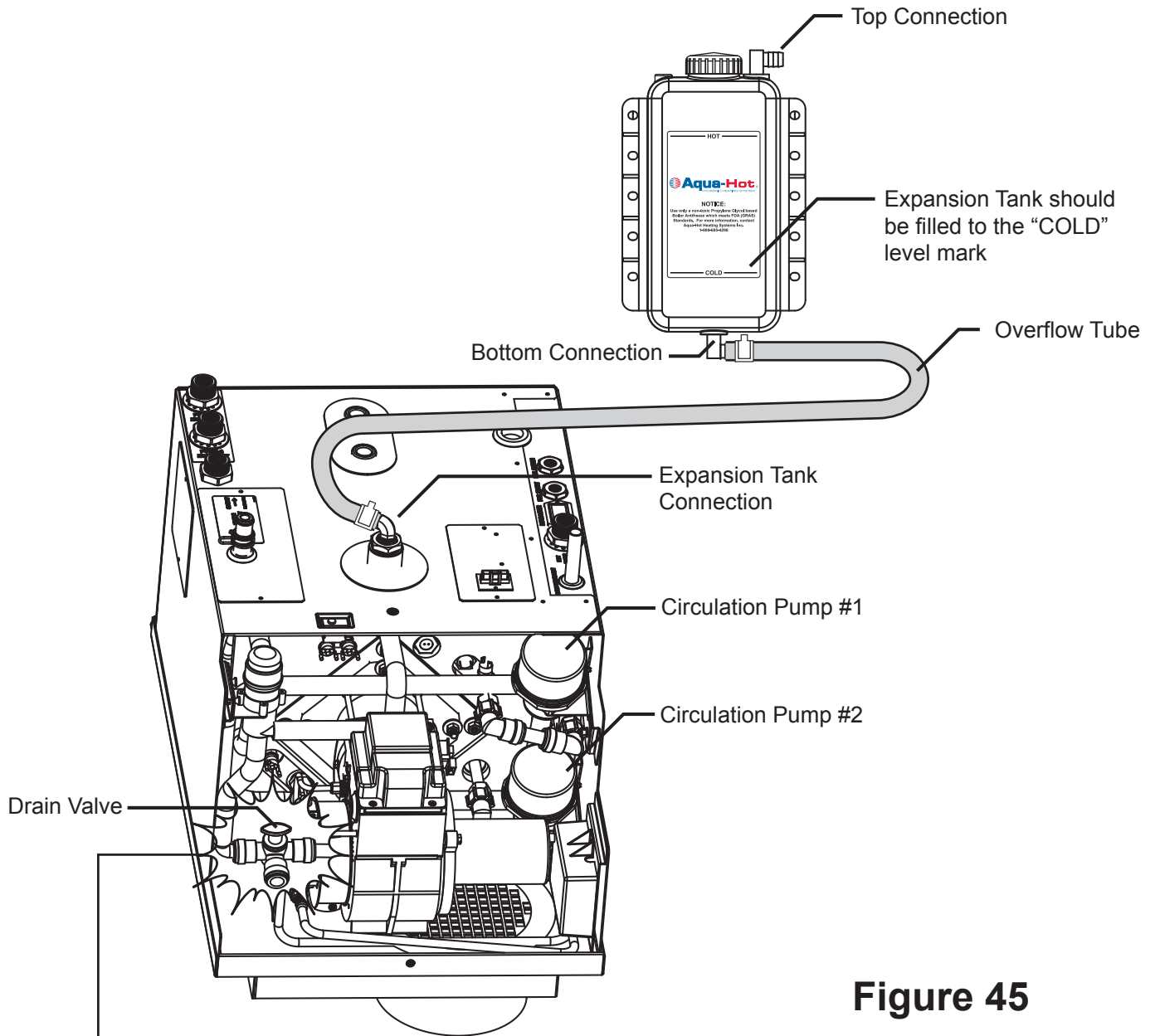
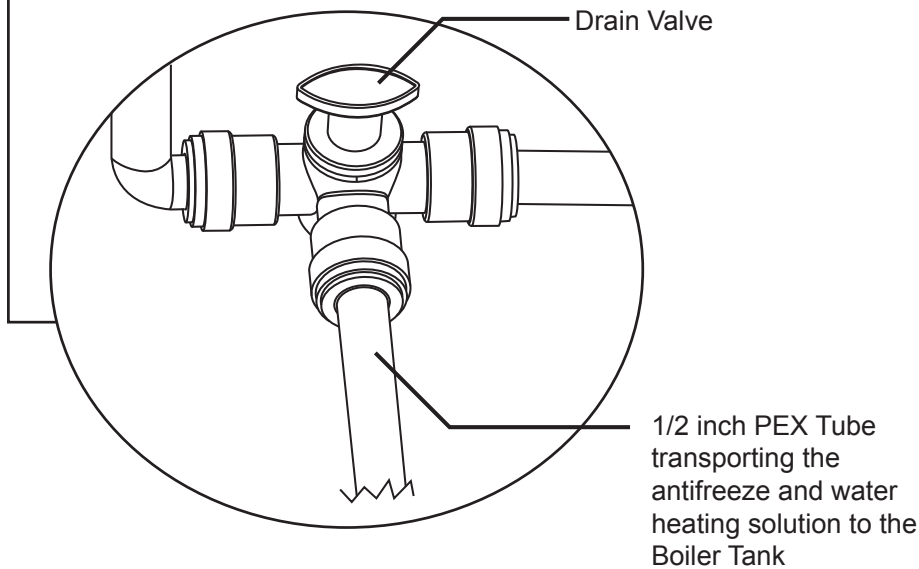

Figure 45



Section 11: Purging the Systems

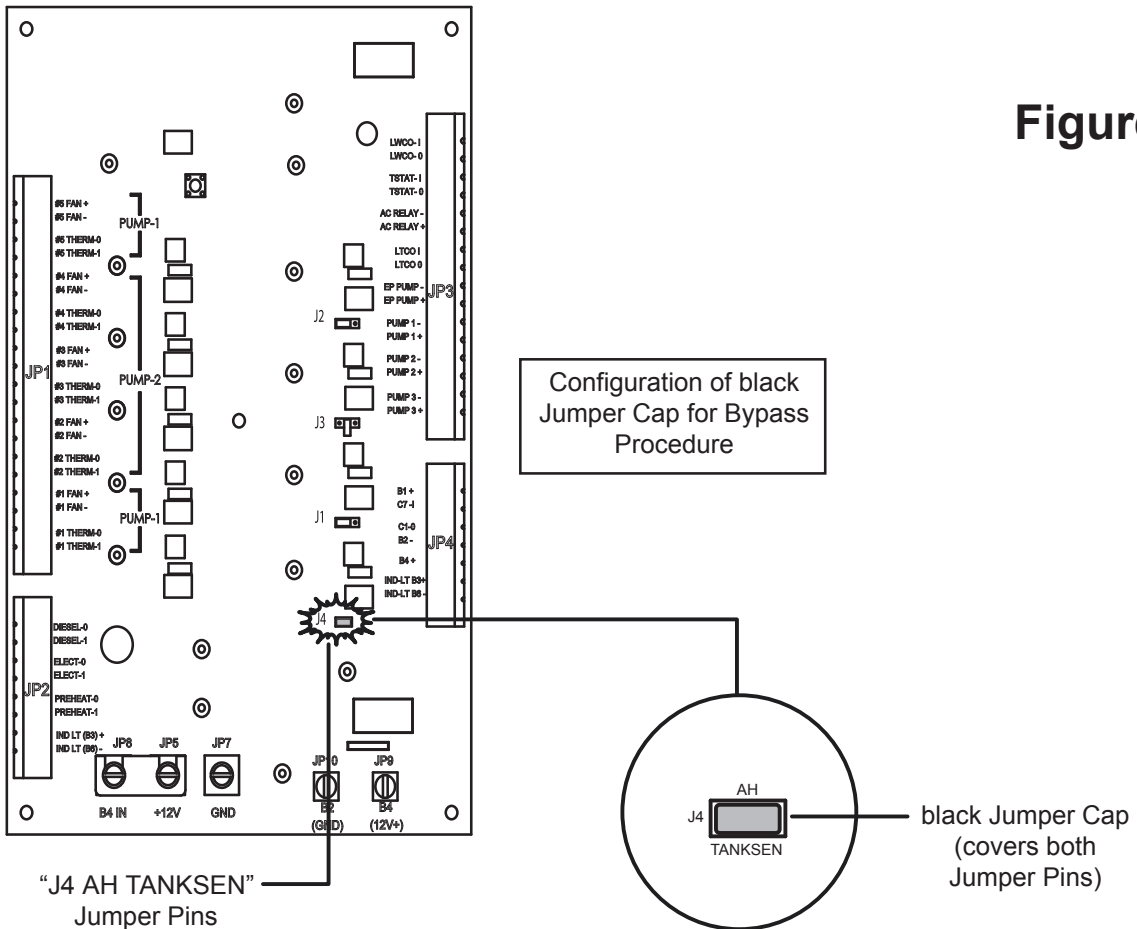
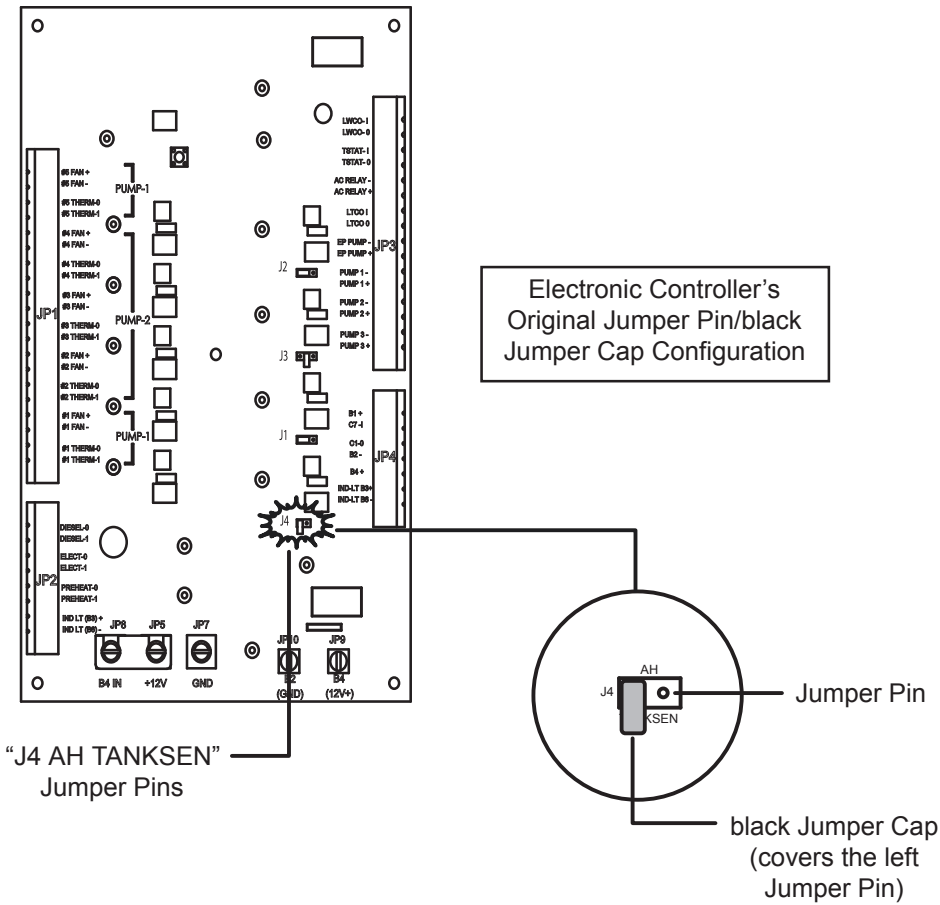

Figure 46

CAUTION:

The Circulation Pump will begin running as soon as the Alligator Clip is connected to a ground source; therefore, be sure to fill the Aqua-Hot's Boiler Tank with the appropriate antifreeze and water heating solution prior to connecting the Circulation Pump to a ground source. Failure to do so could result in damage to the Circulation Pumps.

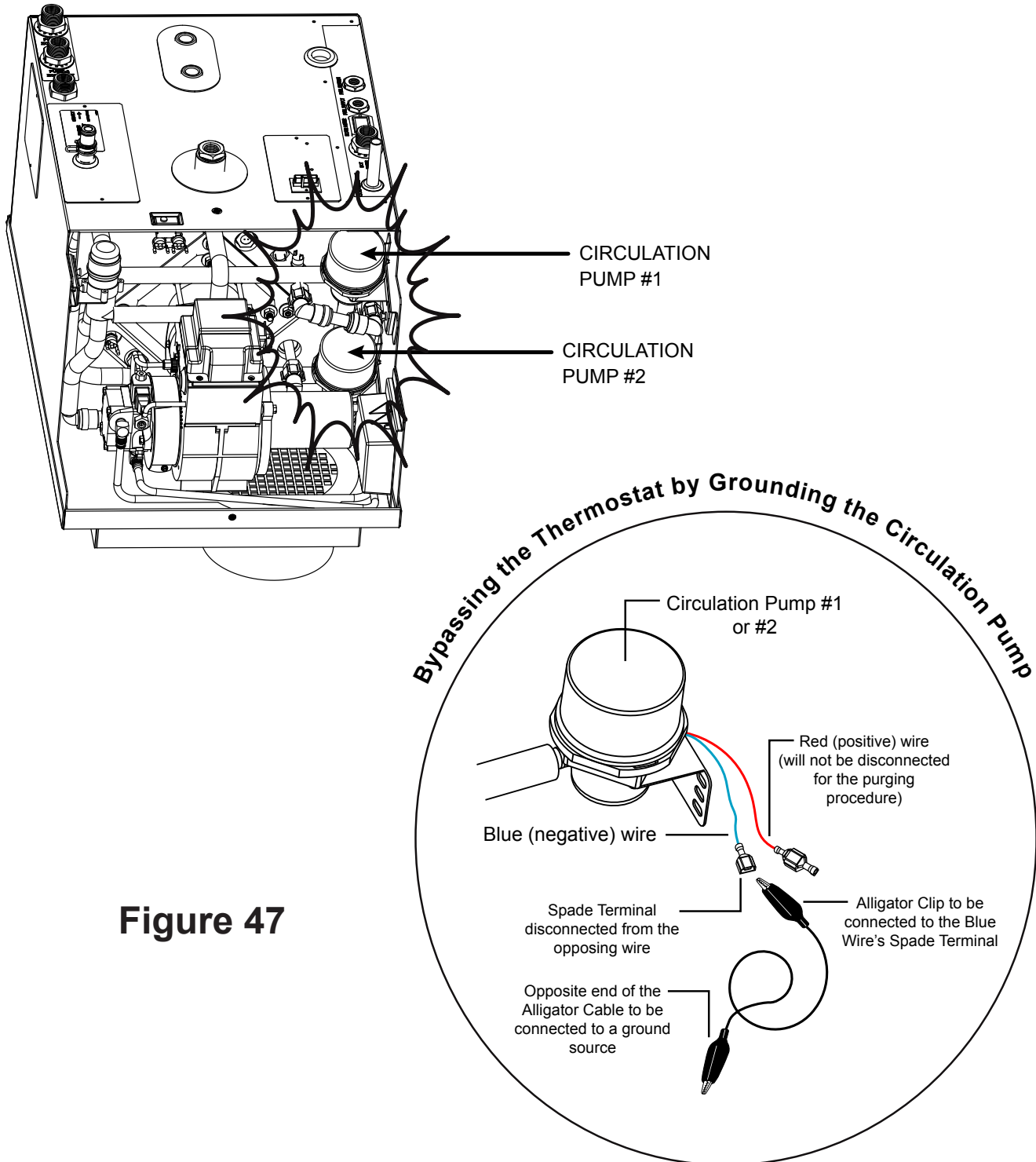

Figure 47

Section 12: Initial Start-Up

Activating the Aqua-Hot:

1. Reinstall the Aqua-Hot's Access Cover and the bolt, which secures the front of the Aqua-Hot's access cover to the mounting tray.

NOTE: The access cover must be installed prior to operation. A safety switch exists which will prevent the Aqua-Hot from operating whenever the Access Cover is not properly installed.

2. Move the "Diesel" switch to the **ON** position for approximately ten seconds **ONLY**, then switch it **OFF**.

NOTE: This procedure will purge the Diesel-Burner's fuel system by allowing the Heater's Fuel Pump to complete its normal 30-150 second shutdown/purge cycle.

3. After the purge cycle has ended, repeat step 1 at least once more.
4. Move the "Diesel" switch to the **ON** position and leave it on in order to activate the Diesel-Burner.

NOTE: It will take approximately 10 seconds before the Diesel-Burner will ignite and exhaust can be heard exiting the heater.

Allow approximately 10-20 minutes for the Aqua-Hot to reach normal operating temperature (approximately 190°F).

5. Move the Aqua-Hot's "Electric" switch to the **ON** position in order to supply 120 Volt-AC power to the Electric Heating Element. The Coach must be connected to shore power or the generator must be running.

NOTE: Both the 12 Volt-DC powered Diesel-Burner and the Electric Heating Element are thermostatically controlled. Either or both heating sources will automatically maintain the temperature of the Boiler Tank's antifreeze and water heating solution.

6. Once the Aqua-Hot internal boiler tank has reached its normal operating temperature of approximately 195°F, switch **ON** each Interior and Fresh Water Tank Thermostat, **one at a time**. Conduct a visual check at actual zone (heat exchangers) to ensure that correct fan is blowing and it is warm air. Also check P.C. Board to ensure proper indicator light is illuminated. This will confirm proper wiring and plumbing. Once you have completed visual check, switch **ON** each thermostat to their maximum temperature settings. This

procedure will activate all Interior and Fresh Water Tank Heat Exchangers in each particular heating zone.

The Aqua-Hot is now ready for normal operation and use.

Switch Panel Blinking Fault Indicator Light

The Interior Switch Panel incorporates a self-diagnostic Blinking Fault Indicator Light, which by using a series of blinking lights, indicates the particular component of the Diesel-Burner that failed during operation.

Each series of blinks are active for 0.5 seconds "**ON**" and 0.5 seconds "**OFF**" with a three-second interval between each Fault Series. This sequence will repeat continuously until the "Diesel-Burner" switch is moved to the "**OFF**" position, the 12 Volt-DC power is disconnected from the Diesel-Burner's Controller, or the Aqua-Hot's access cover is removed.

Should a Diesel-Burner malfunction occur, the Aqua-Hot Hydronic Heating System will cease operation and will activate the appropriate Indicator Light Blinking Fault Sequence. Count the number of flashes, record the number, and contact Aqua-Hot Heating Systems' Application or Sales Department at 1-800-685-4298.

Wiring Diagram

Appendix A: Wiring Diagram

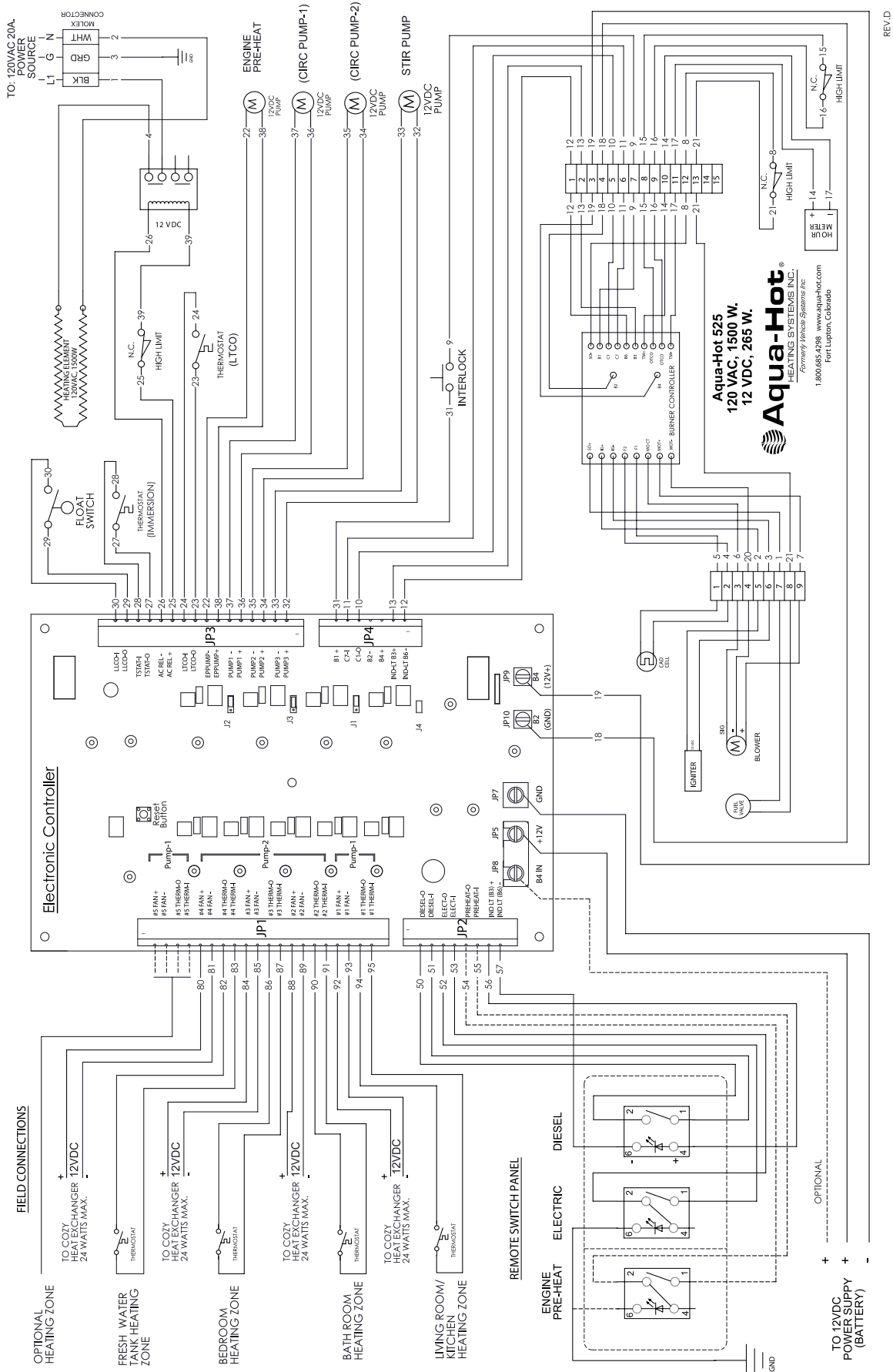

Wire Gauge Information

Appendix B: Wire Gauge Chart

AMERICAN BOAT AND YACHT COUNCIL RECOMMENDATIONS CONDUCTORS SIZES FOR 3% DROP IN VOLTAGE

TOTAL
CURRENT
ON CIRCUIT
IN AMPS.

Length of Conductor from Source of Current to Device and back to Source—Feet

	10	15	20	25	30	40	50	60	70	80	90	100	110	120	130	140	150	160	170	
12 Volts - 3% Drop Wire Sizes (gage) - Based on Minimum CM Area																				
5	18	16	14	12	12	10	10	10	8	8	8	6	6	6	6	6	6	6	6	6
10	14	12	10	10	10	8	6	6	6	6	4	4	4	4	2	2	2	2	2	2
15	12	10	10	8	8	6	6	6	4	4	2	2	2	2	2	1	1	1	1	1
20	10	10	8	6	6	6	4	4	2	2	2	2	1	1	1	0	0	0	0	2/0
25	10	8	6	6	6	4	4	2	2	2	1	1	0	0	0	2/0	2/0	2/0	2/0	3/0
30	10	8	6	6	4	4	2	2	1	1	0	0	0	2/0	2/0	3/0	3/0	3/0	3/0	3/0
40	8	6	6	4	4	2	2	1	0	0	2/0	2/0	3/0	3/0	3/0	4/0	4/0	4/0	4/0	4/0
50	6	6	4	4	2	2	1	0	2/0	2/0	3/0	3/0	4/0	4/0	4/0					
60	6	4	4	2	2	1	0	2/0	3/0	3/0	4/0	4/0	4/0							
70	6	4	2	2	1	0	2/0	3/0	3/0	4/0	4/0									
80	6	4	2	2	1	0	3/0	3/0	4/0	4/0										
90	4	2	2	1	0	2/0	3/0	4/0	4/0											
100	4	2	2	1	0	2/0	3/0	4/0												

	10	15	20	25	30	40	50	60	70	80	90	100	110	120	130	140	150	160	170	
24 Volts - 3% Drop Wire Sizes (gage) - Based on Minimum CM Area																				
5	18	18	18	16	16	14	12	12	12	10	10	10	10	10	8	8	8	8	8	8
10	18	16	14	12	12	10	10	10	8	8	8	6	6	6	6	6	6	6	6	6
15	16	14	12	12	10	10	8	8	6	6	6	6	6	4	4	4	4	4	4	2
20	14	12	10	10	10	8	6	6	6	6	4	4	4	4	2	2	2	2	2	2
25	12	12	10	10	8	6	6	6	4	4	4	4	2	2	2	2	2	2	2	1
30	12	10	10	8	8	6	6	4	4	4	2	2	2	2	2	2	1	1	1	1
40	10	10	8	6	6	6	4	4	2	2	2	2	1	1	1	0	0	0	0	2/0
50	10	8	6	6	6	4	4	2	2	2	1	1	0	0	0	2/0	2/0	2/0	2/0	2/0
60	10	8	6	6	4	4	2	2	1	1	0	0	0	2/0	2/0	3/0	3/0	3/0	3/0	3/0
70	8	6	6	4	4	2	2	1	1	0	0	2/0	2/0	3/0	3/0	3/0	3/0	3/0	4/0	4/0
80	8	6	6	4	4	2	2	1	0	0	2/0	2/0	3/0	3/0	3/0	4/0	4/0	4/0	4/0	4/0
90	8	6	4	4	2	2	1	0	0	2/0	2/0	3/0	3/0	4/0	4/0	4/0	4/0	4/0	4/0	
100	6	6	4	4	2	2	1	0	2/0	2/0	3/0	3/0	4/0	4/0	4/0					

Electronic Controller Features

Appendix C: Electronic Controller Features

“Low Voltage Reset” Feature:

Whenever the Aqua-Hot’s DC power is interrupted, the “Low Voltage Reset” red indicator light on the Electronic Controller will illuminate. Reset the Electronic Controller by pressing the “Low Voltage Reset” button on

the Electronic Controller (use a thin, straight, nonmetallic object to access the button through the faceplate) or by turning **OFF** the “Diesel” switch on the Interior Switch Panel for approximately 30 seconds, then turning the switch back **ON**.

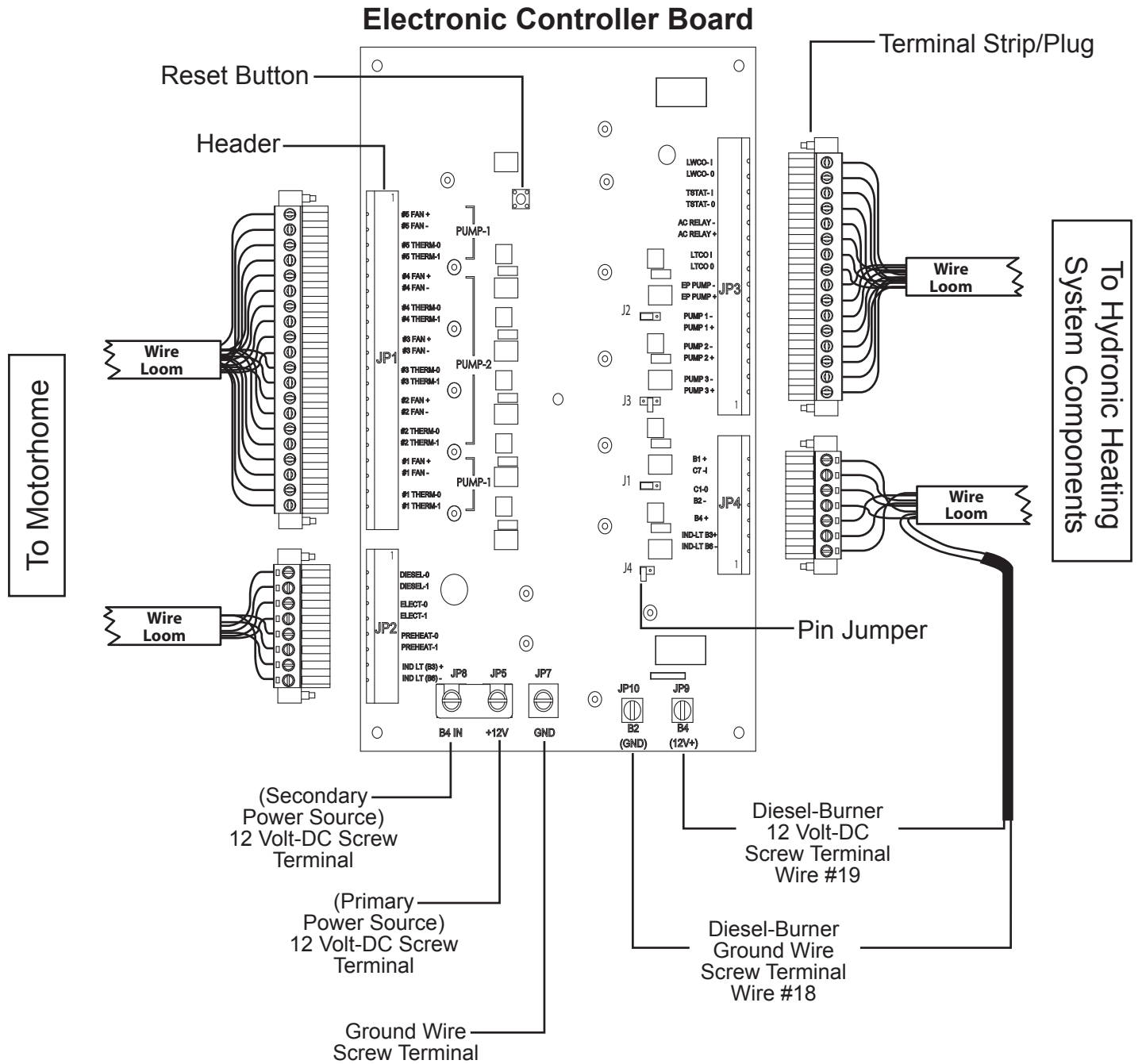

Antifreeze and Water Heating Solution

Appendix D: Antifreeze and Water Heating Solution

Appropriate Water/Propylene Glycol Solution Mixture Ratio:

The following information addresses the process of selecting an antifreeze and water mixture ratio that provides adequate Freeze, Boiling, and Rust/Anti-Corrosive protection. A 50/50 mixture ratio is recommended, which will result in a freeze point of approximately -28°F and a boil point of approximately 222°F.

The following information should be utilized for the purpose of clarifying some terms commonly associated with antifreeze.

Freeze Point and Burst Point:

Antifreeze lowers the freezing point of any liquid, to which it has been added, by preventing the formation of ice crystals; however, as the ambient temperature continues to decline, the water in the solution will attempt to attain a solid state. The point in which the water begins to solidify is termed the “Freeze Point.” Although the water in the solution has begun to freeze, producing a “slushy” consistency, the antifreeze in the solution will continue to combat the normal expansion of the solution as it freezes. The point in which the solution can begin to expand, due to colder temperatures, is called the “Burst Point.” Once the solution reaches the burst point, the potential is present for ruptured pipes to exist. The burst point of the antifreeze and water heating solution is dependent upon the brand of propylene glycol employed.

Boiling Point:

The Aqua-Hot utilizes the antifreeze and water heating solution as a transportation means for the heat produced from the internal processes. The antifreeze absorbs the heat created until its boiling point is reached; it is at this point that the liquid turns to a gas and is expelled to prevent the Heating System from overheating. Each time the boiling point is reached, a loss of efficiency

occurs because the heat produced is expelled rather than utilized for the function of the heating system. Therefore, a higher boiling point is desired in order to combat the loss of efficiency allowing the antifreeze to transport the heat created from the internal process throughout the motorhome where it can be utilized productively rather than dissipating due to its change from a liquid to a gas.

Rust- and Anti-Corrosive Inhibitors:

Another major function of antifreeze is to provide protection to the internal metal components of the Aqua-Hot Hydronic Heating System from corrosion and rust. Antifreeze is able to perform this function by the addition of rust- and anti-corrosive inhibitors, which are designed specifically to activate in a water solution.

Summary:

Antifreeze has three basic functions: freeze protection, boil-over protection, and anti-corrosion and rust protection. Antifreeze is also primarily responsible for heat transfer; however, antifreeze itself does not possess acceptable heat transfer characteristics. Therefore, as water is an excellent heat conductor, it is added to the mixture. A 50/50 solution of propylene glycol antifreeze and water is recommended to provide the best performance combination of the aforementioned functions. If excess propylene glycol exists within an antifreeze and water heating solution, the water’s heat absorption properties are compromised, which could ultimately inhibit the Aqua-Hot from providing adequate domestic hot water and interior heating. Additionally, if the antifreeze and water heating solution contains over 70 percent antifreeze, the freezing point is actually raised resulting in less freeze protection. Please reference the attached graphical representation regarding the percentage of antifreeze to water and how it directly affects the solution’s freezing point.

Appendix D: Antifreeze and Water Heating Solution

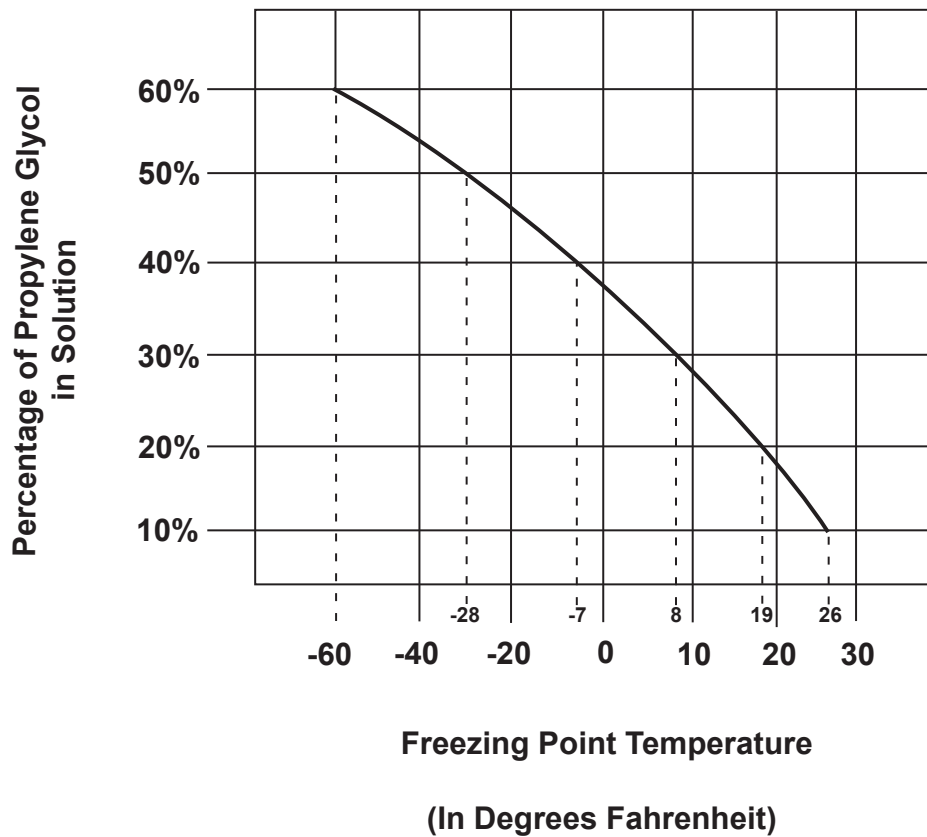

Selecting an Appropriate Propylene Glycol Based Antifreeze:

The following information addresses the necessary usage of a propylene glycol based “boiler” type antifreeze in the Aqua-Hot. Propylene glycol is a safer alternative to the more toxic ethylene glycol antifreeze; however, as mandated by the IAPMO (International Association of Plumbing and Mechanical Officials) only those propylene glycol based “boiler” type antifreezes deemed “Generally Recognized as Safe” (GRAS) by the FDA should be utilized.

Because of the significant impact various types of antifreeze can have on a Hydronic Heating System, including the level of safety provided, it has been recognized that there is a need to provide an explanation regarding two additional prominent types of antifreeze/coolant available. The following information should be utilized as an educational means of ensuring that the proper type of propylene glycol based antifreeze is selected:

RV & Marine Antifreeze:

These types of propylene glycol based antifreeze products are formulated specifically for “winterizing” applications only. Although RV & Marine antifreeze is

often “Generally Recognized as Safe” by the FDA, it should never be used in the Aqua-Hot’s Hydronic Heating System. This type of antifreeze is not formulated to transfer heat, which is essential to the Heating System’s functionality and does not contain rust inhibitors. Please note, however, that RV & Marine antifreeze can be utilized to winterize the Aqua-Hot’s Domestic Hot Water Heating System.

Automotive Antifreeze/Coolant:

These types of propylene glycol based antifreeze products are formulated specifically to protect automotive engines against corrosion, freezing temperatures, and overheating. They also have excellent heat transfer and thermal conductivity characteristics. Although these types of antifreeze products are considered less toxic and safer than ethylene glycol for people, pets, and the environment, they are not “GRAS” (Generally Recognized as Safe) rated by the FDA. Therefore, they must be marked with a “harmful if swallowed” warning. This additional warning is required because these types of antifreeze products contain high levels of chemical rust inhibitors. Due to their potentially hazardous properties, they should never be used in the Aqua-Hot’s Hydronic Heating System.



Formerly Vehicle Systems Inc.

Motorhome Heating Specialist • Manufacturer and Distributor

15549 East Highway 52 • Fort Lupton, Colorado 80621 • 1-800-685-4298 • Fax: 303-857-9000

© Copyright 2005 Aqua-Hot Heating Systems, Inc. All rights reserved.

www.aqua-hot.com

LTE-907-713